

SONY®



LUMA Family Catalog 2009

Professional LCD Monitor

LUMA
Professional LCD Monitor

60P Ready – Sony Continues to Enhance its LUMA Series Professional Monitors



■ High-grade Type Page 4

Since its introduction in 2003, Sony's LUMA™ Series has offered professional monitors in a variety of types and sizes, suitable for applications in the studio and in the field. Building on a long history as a leading supplier of high-definition technology products, Sony continues to enhance its LUMA Series of monitors by introducing three new models: the LMD-2451W*¹ and LMD-940W*² high-grade type monitors and the LMD-1530W*³ entry-level HD monitor.

The LMD-2451W and LMD-940W high-grade type monitors incorporate a newly designed 3G SDI capability. With this feature, these LUMA monitors are able to accept 50P and 60P video signals using only one single SDI cable.

The LMD-1530W is a new 15-inch (viewable area measured diagonally) entry-level HD monitor. This monitor incorporates a 15:9 aspect ratio, WXGA (1280 x 768 resolution) LCD panel, and an HDMI™ interface – in addition to the features offered by the current LMD-1420 SD monitor. It also comes in an almost equivalent size, both in height and width, as to the popular LMD-1420 and LMD-1410 SD monitors. Where smooth migration from the LMD-1420 or LMD-1410 to HD picture monitoring is desired, the LMD-1530W is an ideal choice in terms of product features, operational usability, installation convenience, as well as picture quality.

The LUMA Series LCD monitors continue to meet a variety of picture monitoring applications from broadcast and post-production to surveillance applications.

*1 24-inch viewable area measured diagonally

*2 9-inch viewable area measured diagonally

*3 15.3-inch viewable area measured diagonally



High-grade Type (3G SDI Models)

The LMD-4250W, LMD-2451W, LMD-2050W, LMD-1750W and LMD-940W high-grade type LUMA monitors incorporate the latest DSP engine, the market-proven ChromaTRU™ color-matching technology, and the high functionality for which Sony’s professional video monitors are renowned. These monitors accept a variety of signals in both digital and analog, and HD and SD formats. In particular, the new high-grade type monitors – the LMD-2451W and LMD-940W – offer 3G SDI input capability. These models are Sony’s LCD monitors best-suited for broadcast and post-production applications.

Five Panel Sizes

The high-grade type LUMA monitors are offered in five panel sizes between 42-inch* and 9-inch*.

Model Types

	Panel Resolution	Panel Aspect Ratio	Panel Size*	Desktop Stand	Installation Support	
					19-inch Rack	Mounting Holes (mm)
LMD-4250W	1920 x 1080	16:9	42-inch	N/A	N/A	400 x 400
LMD-2451W	1920 x 1200	16:10	24-inch	Supplied	N/A	100 x 100
LMD-2050W	1680 x 1050	16:10	20-inch	Supplied	Optional MB-529	100 x 100
LMD-1750W	1280 x 768	15:9	17-inch	Optional SU-561	Optional MB-530	75 x 75, 100 x 100
LMD-940W	800 x 480	15:9	9-inch	Supplied	Optional MB-531	N/A

*Viewable area, measured diagonally.



LMD-4250W



LMD-2050W



LMD-2451W



LMD-1750W



LMD-940W

Input Versatility

Multi-format Signal Support – up to 3G SDI Input

The high-grade type LUMA monitors accept almost any SD or HD video format, both analog and digital. These include composite NTSC and PAL, component 480/60i and 575/50i, progressive 480/60P and 576/50P, and high-definition 1080/60i, 1080/50i, 720/60P, 1080/24P, 1080/25P, 1080/30P, 1080/24PsF, and 1080/25PsF. The LMD-2451W and LMD-940W can also accept 1080/50P and 1080/60P formats from a 3G SDI input.

Standard interfaces of the LMD-4250W, LMD-2451W, LMD-2050W and LMD-1750W monitors include analog composite (NTSC/PAL), 525i/625i component and RGB, and Y/C. Additional inputs can be added by using option boards. Digital interfaces including HD-SDI and SD-SDI are also offered as optional boards, to meet budgetary and user needs.

The high-grade type monitors accept various types of analog and digital computer signals via the standard HD-15 and DVI-D*1 interfaces, respectively. With their high-performance scan converters, these monitors can display PC signals from VGA to WUXGA*2.

To provide mobility, the LMD-940W incorporates various video interfaces as standard, including composite, SDI interface*3 for SD-SDI, HD-SDI, 3G SDI, and HDMI interface.

*1 Both 1080/50P and 1080/60P signals are accepted. The images are down-converted for display on the LMD-2050W, LMD-1750W and LMD-940W.

*2 WUXGA images are not accepted by the LMD-4250W, LMD-2050W and LMD-940W. Images ranging from WSXGA+ to 1920 x 1080 are down-converted for display on the LMD-2050W and LMD-940W.

*3 The SD-SDI, HD-SDI and 3G SDI inputs share the same BNC connector, which offers automatic signal detection.

Input Signals/Input Adaptors

Video Signal Formats	Input Signal				Interface and Applicable Models								
	Total Line	Active Line	Aspect Ratio	Frame Rate *1	Composite Y/C	RGB Component	SD-SDI	HD-SDI SD-SDI	Composite Y/C	RGB Component	3G-SDI HD-SDI SD-SDI	HDMI	
					LMD-4250W, LMD-2451W, LMD-2050W, LMD-1750W								
					Standard		Optional BKM-220D	Optional BKM-244CC Optional BKM-243HS	Optional BKM-227W	Optional BKM-229X	Optional BKM-250TG	N/A	
					LMD-940W								
					Standard	N/A	N/A	Standard	N/A	N/A	Standard		
575/50i (PAL)	625	575	16:9 & 4:3	25	○	○	○	○	○	○	○	○	
480/60i (NTSC)	525	483	16:9 & 4:3	30	○	○	○	○	○	○	○*1	○	
576/50p	625	576	16:9 & 4:3	50	N.A.	○	N.A.	N.A.	N.A.	○	N.A.	○	
480/60p	525	483	16:9 & 4:3	60	N.A.	○	N.A.	N.A.	N.A.	○	N.A.	○	
640 x 480/60p*1	525	480	4:3	60	N.A.	N.A.	N.A.	N.A.	N.A.	N.A.	N.A.	○	
1080/24PsF	1125	1080	16:9	24	N.A.	○*2	N.A.	○	N.A.	○*2	○	N.A.	
1080/25PsF	1125	1080	16:9	25	N.A.	○*2	N.A.	○	N.A.	○*2	○	N.A.	
1080/24p	1125	1080	16:9	24	N.A.	○*2	N.A.	○	N.A.	○*2	○	○	
1080/25p	1125	1080	16:9	25	N.A.	○*2	N.A.	○	N.A.	○*2	○	○	
1080/30p	1125	1080	16:9	30	N.A.	○*2	N.A.	○	N.A.	○*2	○	○	
1080/50i	1125	1080	16:9	25	N.A.	○	N.A.	○	N.A.	○	○	○	
1080/60i	1125	1080	16:9	30	N.A.	○	N.A.	○	N.A.	○	○	○	
720/50p	750	720	16:9	50	N.A.	○*2	N.A.	○	N.A.	○*2	○	○	
720/60p	750	720	16:9	60	N.A.	○	N.A.	○	N.A.	○	○	○	
1080/50p	1125	1080	16:9	50	N.A.	N.A.	N.A.	N.A.	N.A.	N.A.	○	○	
1080/60p	1125	1080	16:9	60	N.A.	N.A.	N.A.	N.A.	N.A.	N.A.	○	○	

*1 Compatible with 1/1.001 *2 For component input only

High-grade Type (3G SDI Model)

3G SDI Input

The newly introduced LMD-2451W and LMD-940W monitors have a 3G SDI input capability. On Sony's monitors, the 3G SDI interface is compliant with the SMPTE 425 standard, transmitting up to 4:2:2/10-bit 1080/60P video data using one SDI cable. This single-link system is known as a SD-SDI or HD-SDI system, but it can also handle both Dual-Link HD-SDI and 3G SDI video data with the use of Sony's 3G SDI interface. This 3G SDI interface enables LMD-2451W and LMD-940W monitors to accept 50P and 60P*

video data. Where an upgrade to a Dual-Link HD-SDI system is necessary, this single-link 3G SDI system is also the ideal alternative.

As with other interface boards, the 3G SDI interface is offered as an optional item (BKM-250TG) – for the LMD-2451W, while the 9-inch LMD-940W monitor incorporates the 3G SDI interface as standard.

* 50P/60P images are reproduced without the delay caused by the V/P-conversion process.



LMD-2451W with the BKM-250TG 3G SDI board

Signal-interface Options

The LMD-4250W, LMD-2451W, LMD-2050W and LMD-1750W monitors accept HD-SDI and SD-SDI signals via the following optional input adaptors. The LMD-2451W monitor can also accept 50P and 60P signals via the BKM-250TG 3G SDI optional input adaptor.



Connector Panel

BKM-250TG*

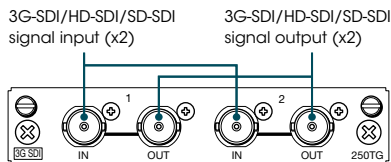

3G/HD/SD-SDI Input Adaptor

- 3G/HD/SD-SDI signal input (x 2)
- 3G/HD/SD-SDI monitor output (x 2)
- Power consumption: Approx. 4 W
- * 3G-SDI, HD-SDI and SD-SDI signals are detected automatically.

BKM-243HS

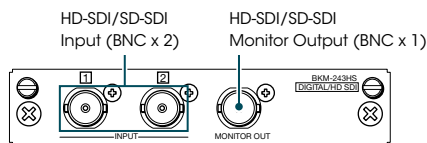

HD-SDI/SD-SDI Input Adaptor*

- HD-SDI/SD-SDI signal input (x2)
- HD-SDI/SD-SDI monitor output (x1)
- Power consumption: 2.0 W
- * HD-SDI and SD-SDI signals are detected automatically.

BKM-229X

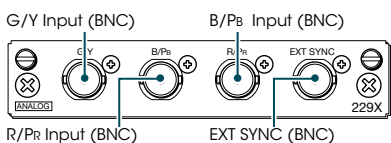

Analog Component Adaptor

- RGB/ Y/PB/PR input connector (x1)
- EXT SYNC (x1)
- Power consumption: 4.0 W

BKM-244CC

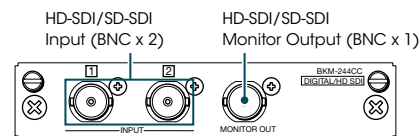

HD/SD-SDI Closed Caption Adaptor*

- HD-SDI/SD-SDI signal input (x2)
- HD-SDI/SD-SDI monitor output (x1)
- Power consumption: 3.8 W
- * Both EIA 608 and EIA 708 Closed caption decoders are equipped.
- * HD-SDI and SD-SDI signals are detected automatically.

BKM-220D

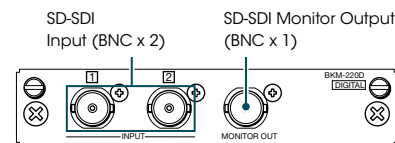

SD-SDI 4:2:2 Input Adaptor*

- SD-SDI signal input (x2)
- SD-SDI monitor output (x1)
- Power consumption: 1.5 W
- * Embedded audio is supported.

BKM-227W

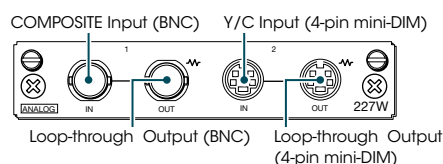

NTSC/PAL Input Adaptor

- Composite input/output (x1)
- Y/C input/output (x1)
- Power consumption: 1.8 W

LMD-4250W Connector Panel and Option Slots

Preset Computer Input Frequencies

The high-grade type LUMA monitors* are factory preset to accept the following typical computer input signal frequencies:

* The LMD-940W monitor does not come equipped with the HD15 interface.

HD15 Input Signal Format

Resolution	H Total	H addr.	V Total	V Addr.	Dot Clock	fH	fV	Sync Polarity		LMD-4250W	LMD-2451W	LMD-2050W	LMD-1750W
					[MHz]	[kHz]	[Hz]	Horizontal	Vertical				
640x480@60Hz*	800	640	525	480	25.175	31.469	59.940	N	N	○	○	○	○
640x480@60Hz	800	640	494	480	23.625	29.531	59.780	P	N	○	○	○	○
720x400@70Hz*2	900	720	449	400	28.322	31.469	70.087	N	P	○	○	○	○
800x600@56Hz*	1024	800	625	600	36.000	35.156	56.250	P	P	○	○	○	○
800x600@60Hz*	1056	800	628	600	40.000	37.879	60.317	P	P	○	○	○	○
800x600@60Hz	960	800	618	600	35.500	36.979	59.837	P	N	○	○	○	○
800x600@72Hz*	1040	800	666	600	50.000	48.077	72.188	P	P	○	○	○	○
800x600@75Hz*	1056	800	625	600	49.500	46.875	75.000	P	P	○	○	○	○
800x600@85Hz*	1048	800	631	600	56.250	53.674	85.061	P	P	○	○	○	○
1024x768@60Hz*	1344	1024	806	768	65.000	48.363	60.004	N	N	○	○	○	○
1024x768@60Hz	1184	1024	790	768	56.000	47.297	59.870	P	N	○	○	○	○
1024x768@70Hz*	1328	1024	806	768	75.000	56.476	70.069	N	N	○	○	○	○
1024x768@75Hz*	1312	1024	800	768	78.750	60.023	75.029	P	P	○	○	○	○
1024x768@85Hz*	1376	1024	808	768	94.500	68.677	84.997	P	P	○	○	○	○
1152x864@75Hz*	1600	1152	900	864	108.000	67.500	75.000	P	P	○	○	○	○
1280x768@50Hz	1648	1280	791	768	65.125	39.518	49.959	N	P	○	○	○	○
1280x768@60Hz	1680	1280	795	768	80.125	47.693	59.992	N	P	○	○	○	○
1280x768@60Hz	1440	1280	790	768	68.250	47.396	59.995	P	N	○	○	○	○
1280x768@75Hz	1712	1280	802	768	102.875	60.091	74.926	N	P	○	○	○	○
1280x800@60Hz*1					68.900	48.935	59.969	N	N	○	○	○	○
1280x960@60Hz*	1800	1280	1000	960	108.000	60.000	60.000	P	P	○	○	○	○
1280x960@60Hz	1440	1280	988	960	85.250	59.201	59.920	P	N	○	○		
1280x1024@60Hz*	1688	1280	1066	1024	108.000	63.981	60.020	P	P	○	○	○	○
1280x1024@60Hz	1440	1280	1054	1024	91.000	63.194	59.957	P	N	○	○	○	○
1360x768@50Hz	1760	1360	791	768	69.500	39.489	49.922	N	P	○	○	○	○
1360x768@60Hz	1776	1360	768	768	84.625	47.649	59.936	N	P	○	○	○	○
1360x768@60Hz	1520	1360	790	768	72.000	47.368	59.960	P	N	○	○	○	○
1600x1200@50Hz	2144	1600	1235	1200	132.375	61.742	49.994	N	P		○		
1600x1200@60Hz	1760	1600	1235	1200	130.375	74.077	59.981	P	N		○		
1920x1080@50Hz	2544	1920	1112	1080	141.375	55.572	49.975	N	P	○	○	○	○
1920x1200@50Hz	2560	1920	1235	1200	158.000	61.719	49.975	N	P		○		
1920x1080@60Hz	2080	1920	1111	1080	138.625	66.647	59.988	P	N	○	○	○	○

○=VESA-DMT ○=VESA-CVT VCRT N = Negative P = Positive * SOG *1 Anycast Station *2 Matrix



LMD-2451W/LMD-2050W Connector Panel



LMD-940W Connector Panel



LMD-2451W/LMD-2050W Option Slots



LMD-1750W Connector Panel and Option Slots

High-grade Type (3G SDI Model)

Superb Picture Performance

High Purity Color Filters

The high-grade type LUMA monitors use precisely manufactured RGB color filters, allowing the reproduction of colors with stunning depth and saturation to create highly natural images.

Accurate Gamma and Stable White Balance - ChromaTRU™ Color Processing

For an extra level of color-reproduction accuracy, every LCD panel used in the high-grade type LUMA monitors is precisely color calibrated at the factory, providing characteristics consistent with those of CRT displays.



The colorimetry of an LCD display, by nature, can exhibit inaccurate R, G, B color coordinates and unbalanced R, G, B gamma curves, which can make precise color matching between multiple monitors a challenge. These are also the primary reasons why LCD color tone can differ slightly from CRT tone. The high-grade type LUMA monitors solve this problem by precisely calibrating each LCD panel's light output so that the R, G, B color coordinates are virtually the same as those of a CRT monitor. A second calibration is further applied so that white balance is maintained at a consistent color temperature throughout all grayscale levels. The result of these precise calibrations is color reproduction reminiscent of Sony's CRT displays.

Sophisticated I/P Conversion

The high-grade type LUMA monitors use a motion-adaptive I/P-conversion process to achieve conversion results that are optimized to the picture content - whether it is static or dynamic. Highly accurate I/P conversion is provided regardless of signal resolution, for example, whether the input is HD or SD.

Excellent Brightness and Contrast

The high-grade type LUMA monitors provide high-brightness, high-contrast images by utilizing super-wide aperture LCD panels.

Extremely Wide Viewing Angle

The high-grade type LUMA monitors offer the most stable images within the LUMA Series when viewed from various angles. They offer wide viewing angles both horizontally and vertically, with virtually no reduction in picture contrast, color saturation and hue shift. This allows precise images to be clearly viewed from various positions and angles - a critical requirement in professional video monitoring.

The CIE $u'v'$ chart is used to evaluate the light output of display devices. In this diagram, the raw light output of a LUMA LCD panel is compared with that of a CRT from Sony. The triangular areas show their different color reproduction capabilities (Color Space). The green and red dots indicate the color of light output from the LUMA LCD panel and from the CRT for certain RGB input signals. Note that the same light color is not obtained for the same video input. The ChromaTRU process, on the other hand, reproduces consistent light output extremely close to that of a CRT.



AR (anti-reflection) Coated Protection Panel*

The LMD-940W monitor uses robust AR-coated protection layers, which minimize the chance of the panel being scratched during transportation – an extremely important criteria for use in the field or in any mobile application. The AR coating additionally has two unique characteristics: it provides a high transmission rate of the internal light source to keep the picture as bright as possible, and it keeps reflection from ambient light to a minimum. As a result, when used in bright lighting conditions, high contrast is still maintained even in dark areas of the picture.

*This protection panel is detachable.

Excellent Picture Quality (NTSC video) (LMD-940W)

While designed for portable high-definition picture monitoring, the LMD-940W can also reproduce the most stunning NTSC composite images ever seen on a LUMA Series monitor thanks to its WVGA (800 x 480) panel.



LMD-940W

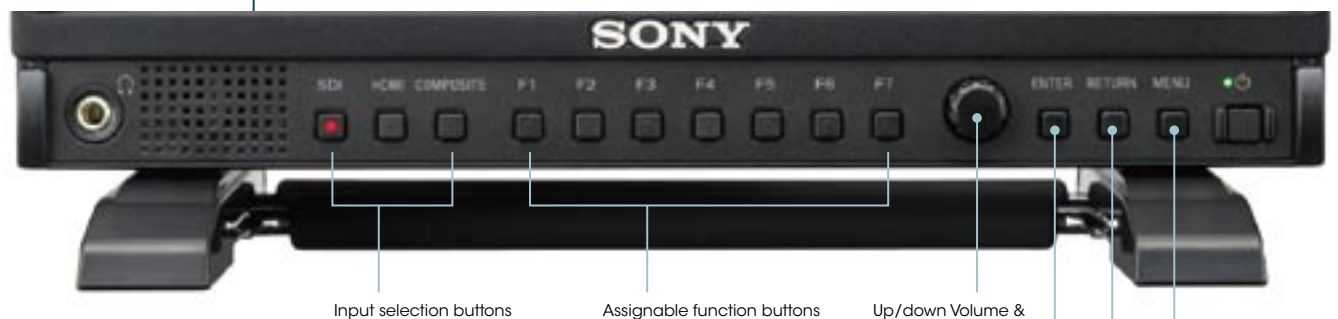

LMD-940W Control Panel

Input selection buttons

Assignable function buttons

- Default setting:
- F1 (BRIGHTNESS)
- F2 (CONTRAST)
- F3 (CHROMA)
- F4 (SCAN)
- F5 (H/V DELAY)
- F6 (VOLUME)
- F7 (I/P MODE*)

*Picture Delay Minimum Mode

Up/down Volume & Enter/set button

Enter/set button

Return button

Menu on/off button

Operational Convenience

Advanced Marker Settings

The high-grade type LUMA monitors can display various area markers, including a center marker, aspect markers, and a safety zone* marker. The brightness of these markers can be selected from three different levels: white, gray, and dark gray. Users can also select either a black or gray matte to fill the outer area of the aspect markers. These flexible marker controls, together with the choice of many different aspect markers, make the high-grade type LUMA monitors extremely convenient display devices for a variety of shooting scenarios – from standard video acquisition to digital cinematography.

*LMD-940W does not support the safety zone marker.

Marker Variation

	16:9 Mode	4:3 Mode
Aspect Marker	4:3, 15:9, 14:9, 13:9, 1.85:1, 2.35:1, 1.85:1 & 4:3	16:9
Center Marker	○	
Safety Area	80%, 85%, 88%, 90%, 93%	

New sub control design (LMD-940W)

In addition to the familiar OSD operation, the LUMA Series monitors offer control panels on the monitor bezel. The LMD-940W incorporates a new control-panel design. By assigning monitor functions* to each of its seven function buttons respectively, users can customize the LMD-940W for a specific application or usage such as field and studio use.

*Brightness, Contrast, Chroma, Scan, H/V Delay, Volume, and I/P Mode are assignable.

High-grade Type (3G SDI Model)

Color Temperature

With the high-grade type LUMA monitors, color temperatures of 9300k, 6500k, or a user preset value can be selected.

Selectable Scan Size for Video Input and Aspect Ratio

With the high-grade type LUMA monitors, the scan size can be selected between 5% over scan and 0% scan modes. The aspect ratio can be switched between 16:9 and 4:3 according to the input signal.

Three-color Tally

With the high-grade type LUMA monitors, the LMD-2451W, LMD-2050W, LMD-1750W and LMD-940W come equipped with a tally lamp that can be lit via a parallel remote connector. The status of the signal displayed on the monitor can be identified by the tally color – red, green, or amber.

Smart APA (Auto Pixel Alignment) for Computer Input

The image size can be automatically adjusted to its optimal setting with the one-touch APA key.

Parallel and Serial Remote Control

The high-grade type LUMA monitors can be controlled remotely via a parallel and serial remote connector. There are 38 functions*¹ in the parallel remote menu (such as the ability to switch input signals), of which eight can be allocated to the connector. The serial remote controls are supported via the Ethernet and RS-232C*² command.

*¹ The LMD-4250W offers 35 functions and the LMD-940W offers 27 functions.

*² Not available on the LMD-940W monitor.

Stereo Audio Monitoring

The high-grade type LUMA monitors* are equipped with stereo speakers (1.0 W + 1.0 W), which enable the user to monitor audio.

*The LMD-940W is equipped with a speaker (0.5W) as well as a head phone jack.

Protected Controls

With the high-grade type LUMA monitors, the key-inhibit function helps prevent inadvertent operation from the control panel.

Closed-Caption Decoder*¹

The high-grade type LUMA monitors are equipped with closed caption decoders. The closed caption information embedded in EIA 608 and EIA 708*² can be decoded for display.

*¹ The LMD-940W is not equipped with the closed caption decoders.

*² For EIA708, the optional Closed Caption Adaptor BKM-244CC is required.

Convenient Installation

Mounting Flexibility

Mountable in a 19-inch EIA Standard Rack (LMD-2050W, LMD-1750W and LMD-940W)

Although wider than a 19-inch rack, the LMD-2050W (8U high) can be rack mounted using the optional MB-529 Mounting Bracket. The LMD-1750W (7U high) can also be rack mounted using the optional MB-530 Mounting Bracket. The LMD-940W is 4U high and half-rack wide. Using the optional MB-531 Mounting Bracket with a 10-degree-forward and 10-degree-backward nonstop-tilt capability, two units can be installed side by side in a 19-inch EIA standard rack.



LMD-940W and the MB-532 Mounting Panel installed in the MB-531 19" Mounting Bracket

VESA® Mounting

(LMD-2451W, LMD-2050W and LMD-1750W)

Complying with VESA standards, the LMD-2451W, LMD-2050W, and LMD-1750W monitors can easily be mounted on a wall or ceiling.

Mounting holes for the LMD-4250W

The LMD-4250W also offers mounting installation capability, which uses 4 pieces of the VESA type screws.

*400 x 400 mm pitch

Screw holes for Camera Pedestal (LMD-940W)

The LMD-940W monitor has 3/8-inch and 1/4-inch screw holes on the bottom. These allow the LMD-940W monitor to be installed in a camera system, for example, by mounting it on a camera pedestal. The LMD-940W can also control and increase the aperture level of a video signal to help camera focus operation.

LMD-940W Rear and Bottom



1/4 inch hole
3/4 inch hole

ENG Kit VF-510 (LMD-940W only)

The LMD-940W monitor is a strategic choice for use in ENG and EFP field operations. When compared to CRT displays, the picture contrast of these monitors is affected less by ambient light, allowing clear images to be viewed even under strong sunlight. For further protection, the optional VF-510 ENG Kit provides a Viewing Hood, Carrying Handle, and Connector Protector.



LMD-940W with the VF-510 ENG Kit

Other Features

- WFM and Audio Level Meter*¹ Windows (LMD-2451W, LMD-2050W, LMD-1750W and LMD-940W)
- Picture by Picture mode*²
- H/V Delay Function
- ACC Off
- DC Operation (24V: LMD-2451W and LMD-2050W, 12V: LMD-1750W, 12V: LMD-940W)
- Setup Level for Analog Component and NTSC signal
- Sub Control on Contrast, Chroma, Phase, and Brightness
- Blue-Only Mode
- Monochrome Mode
- Auto Chroma/Phase Setup
- DVI-D Input*²
- Power-saving Function (computer input only)*²
- DDC-2B*²

*¹ Only embedded audio is supported.

*² Not supported on the LMD-940W.



Entry-level Type

The LMD-2030W, LMD-1530W and the LMD-9020 offer the best quality-per-cost balance for entry-level HD applications. Both the LMD-2030W and LMD-1530W can accept HD signals via their HDMI interface or analog component connectors, while the LMD-9020 can accept HD signals via its analog component connectors. The newly introduced LMD-1530W comes in nearly the same size, both height and width, as the popular LMD-1420 and LMD-1410 SD monitors. The LMD-9020 can be AC or DC driven, and can be hand-held, situated on a desk, or mounted in standard EIA racks, in the field and the studio.

Also, the entry-level type LUMA monitors provide the same proven user-friendly features of Sony's professional monitors for convenient monitoring in wedding and event videography, and many other applications.

Three Panel Sizes

The entry-level type LUMA monitors are offered in three versions: the LMD-2030W, the new LMD-1530W, and the LMD-9020 monitor.

Model Types

	Panel Resolution	Panel Aspect Ratio	Panel Size *	Desktop Stand	Installation Support	
					19-inch Rack	Mounting Holes (mm)
LMD-2030W	1680 x 1050	16:10	20-inch	Supplied	Optional MB-529	100 x 100
LMD-1530W	1280 x 768	15:9	15.3-inch	Supplied	Optional MB-533	100 x 100
LMD-9020	640 x 480	4:3	8.4-inch	Supplied	Optional MB-525	N/A

* Viewable area, measured diagonally.



LMD-2030W



LMD-1530W



LMD-9020

Input Versatility

All entry-level type LUMA monitors come equipped with a full range of analog SD inputs including analog composite NTSC and PAL, Y/C (S-Video), and 525i/625i component and RGB. The LMD-2030W and LMD-1530W further handle SD-SDI input by using the optional BKM-320D SD-SDI input adaptor.

To keep the unit simple and clean, the LMD-9020 monitor provides all inputs built-in as standard. For typical SD video monitoring, the LMD-9020 offers almost all analog SD interfaces including composite (NTSC/PAL), Y/C, and analog component/RGB interfaces.

Furthermore, the LMD-2030W and LMD-1530W offer an HD signal input capability via its HDMI and analog component

interface, and the LMD-9020 can accept an HD signal input via its analog component interface. Also the LMD-2030W and LMD-1530W can accept DVI signals via the HDMI interface*.

*A DVI conversion cable is required.

	Interface			
	Composite Y/C	RGB Component	SD-SDI	HDMI
LMD-2030W	○	○	Optional BKM-320D	○
LMD-1530W	○	○		○
LMD-9020	○	○	N/A	N/A

Video Input Signals/Input Adaptors

Input Signal				Interface			
System	Total Line	Active Line	Aspect Ratio	Composite Y/C	RGB Component	SD-SDI	HDMI
				Standard		Optional BKM-320D	Standard
Model				LMD-2030W LMD-1530W LMD-9020	LMD-2030W LMD-1530W LMD-9020	LMD-2030W LMD-1530W	LMD-2030W LMD-1530W
575/50i (PAL)	625	575	16:9/4:3	○	○	○	○*3
480/60i (NTSC)*1	525	483	16:9/4:3	○	○	○	○*4
576/50P	625	576	16:9/4:3	N.A.	○*5	N.A.	○
480/60P	525	483	16:9/4:3	N.A.	○*5	N.A.	○
1080/24P*1	1125	1080	16:9	N.A.	○*2 *5	N.A.	○
1080/25P	1125	1080	16:9	N.A.	○*2 *5	N.A.	○
1080/30P*1	1125	1080	16:9	N.A.	○*2 *5	N.A.	○
1080/50i	1125	1080	16:9	N.A.	○*2 *5	N.A.	○
1080/60i*1	1125	1080	16:9	N.A.	○*5	N.A.	○
720/50P	750	720	16:9	N.A.	○*2 *5	N.A.	○
720/60P*1	750	720	16:9	N.A.	○*5	N.A.	○

*1 The frame rate is also compatible with 1/1.001 frame rates. *2 Component signals only. *3 720 (1440) x 576i @ 50 Hz.

*4 720 (1440) x 480i @ 59.94/60 Hz. *5 LMD-2030W and LMD-1530W only.

LMD-2030W, LMD-1530W DVI Input Signals

Resolution	Dot clock (MHz)	fH (kHz)	fV (Hz)	LMD-2030W	LMD-1530W
720 x 400 70Hz	28.322	31.469	70.087	○	○
800 x 600 56Hz	36.000	35.156	56.250	○	○
800 x 600 60Hz	40.000	37.879	60.317	○	○
1024 x 768 60Hz	65.000	48.363	60.004	○	○
1280 x 768 60Hz	79.500	47.776	59.870	-	○
1360 x 768 60Hz	85.500	47.712	60.015	○	-

*A DVI conversion cable is required.

Entry-level Type

Connector Panel

LMD-2030W

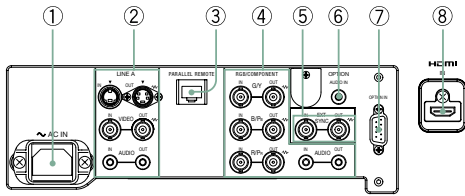

- ① AC In
- ② Line A [Composite (BNC), Y/C (4-pin mini-DIN), Audio (RCA phono jack)]
- ③ PARALLEL REMOTE (modular connector)
- ④ RGB/COMPONENT [BNC, Audio (RCA phono jack)]
- ⑤ EXY SYNC In/Out (BNC)
- ⑥ OPTION Audio In (RCA phono jack)
- ⑦ OPTION In connector for SD-SDI board (BKM-320D)
- ⑧ HDMI



LMD-2030W

LMD-1530W

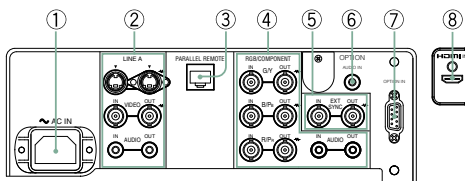

- ① AC In
- ② Line A [Composite (BNC), Y/C (4-pin mini-DIN), Audio (RCA phono jack)]
- ③ PARALLEL REMOTE (modular connector)
- ④ RGB/COMPONENT [BNC, Audio (RCA phono jack)]
- ⑤ EXY SYNC In/Out (BNC)
- ⑥ OPTION Audio In (RCA phono jack)
- ⑦ OPTION In connector for SD-SDI board (BKM-320D)
- ⑧ HDMI



LMD-1530W

LMD-9020

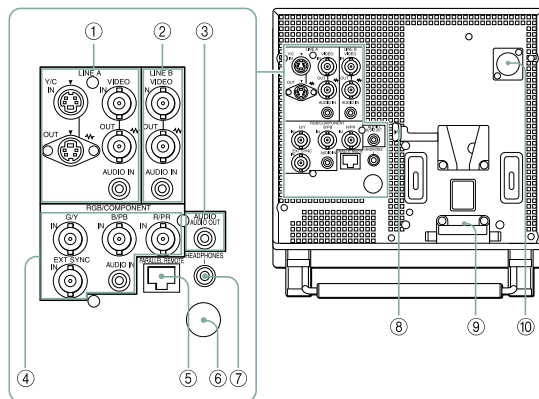

- ① Line A
 - Y/C In/Out (4-pin mini-DIN x 2)
 - Composite In/Out (BNC x2)
 - Audio In (mini jack x2)
- ② Line B
 - Composite In/Out (BNC x2)
 - Audio In (mini jack x2)
- ③ Audio Out (mini jack)
- ④ RGB Component
 - G/Y, B/PB, R/PR In (BNC x3)
 - Ext Sync (BNC)
 - Audio In (mini jack)
- ⑤ Parallel Remote (modular 8-pin)
- ⑥ Service Terminal
- ⑦ Headphones Jack
- ⑧ AC Adapter Eject
- ⑨ AC Adaptor Attachment place
- ⑩ DC 12V In (XLR-type 4-pin)

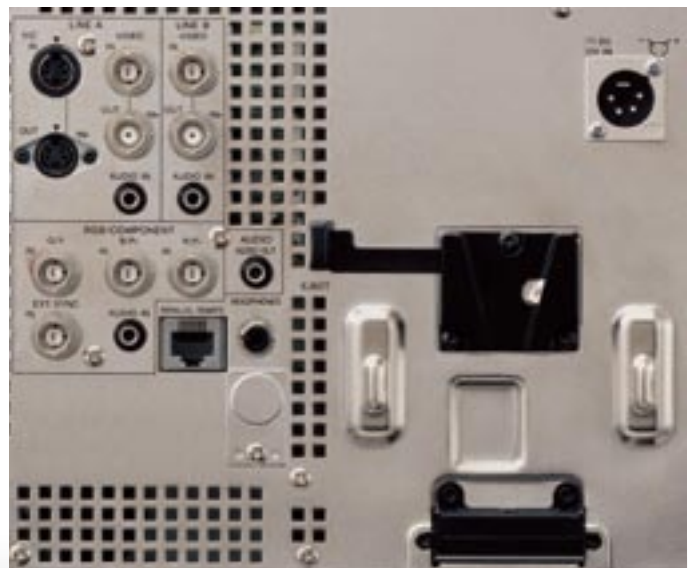

LMD-9020

High Picture Performance

High Purity Color Filters

The entry-level type LUMA monitors come equipped with high-purity RGB color filters, allowing the reproduction of colors with stunning depth and saturation.

Excellent Brightness and Contrast

The entry-level type LUMA monitors provide high-brightness, high-contrast images thanks to their wide aperture LCD panels. In addition, the use of precisely manufactured RGB color filters allows these monitors to reproduce colors with stunning depth and saturation – creating highly natural images.

Wide Viewing Angle

The LCD panels used in the entry-level type LUMA monitors provide a wide viewing angle of 178 degrees for the LMD-2030W, 176 degrees for the LMD-1530W, and 170 degrees for the LMD-9020, both horizontally and vertically, with minimal reduction in picture contrast. This allows images to be viewed from various positions and angles.

AR (anti-reflection) Coated Protection Panel (LMD-9020)

The LMD-9020 monitor uses robust AR-coated protection layers, which minimize the chance of its panel being scratched during transportation – an extremely important criteria for use in the field or in any mobile application. The AR coating additionally has two unique characteristics: it provides a high transmission rate of the internal light source to keep the picture as bright as possible, and it keeps reflection from ambient light to a minimum. As a result, when used in bright lighting conditions, high contrast is still maintained even in dark areas of the picture.

Operational Convenience

Advanced Marker Settings

The LMD-2030W, LMD-1530W and LMD-9020 can display various area markers, including a center marker and aspect markers. The brightness of these markers can be selected from three different levels: white, gray, and dark gray. Users can also select either a black or gray matte to fill the outer area of the aspect markers. These flexible marker controls, together with the choice of many different aspect markers, make these monitors extremely convenient display devices for a variety of shooting scenarios.

Marker Variation

		16:9 Mode	4:3 Mode
Aspect Marker	LMD-2030W LMD-1530W	4:3	16:9
	LMD-9020	4:3, 15:9, 13:9, 1.85:1, 2.35:1, 1.85:1 & 4:3	
Center Marker	LMD-2030W LMD-1530W LMD-9020	○	

Color Temperature/Gamma Selection

With the entry-level type LUMA monitors, users can select from high, low, or preset color temperatures. A variety of gamma modes can also be selected.

Selectable Scan Size for Video Input and Aspect Ratio

With the entry-level type LUMA monitors, the scan size can be selected from 5% over-scan and -3% under-scan modes. The aspect ratio can be switched between 16:9 and 4:3 according to the input signal.

Three-color Tally

The LMD-2030W, LMD-1530W and LMD-9020 come equipped with a tally lamp that can be lit via a parallel remote connector. The status of the signal displayed on the monitor can be identified by the tally color: red, green, or amber.

Parallel Remote Control

The entry-level type LUMA monitors can be controlled remotely via their parallel remote connectors. In the remote menu, there are 17 functions for the LMD-2030W/LMD-1530W and 27 for the LMD-9020 (such as the ability to switch input signals), of which seven can be allocated to the remote connector.

Monaural Audio Monitoring

All entry-level type LUMA monitors are equipped with a speaker (0.5 W), which enables the user to monitor audio.

Entry-level Type

Protected Controls

With the entry-level type LUMA monitors, the key-inhibit function helps prevent inadvertent operation from the control panel.

ENG Kit VF-509

The LMD-9020 monitor is a strategic choice for use in ENG and EFP field operations. When compared to CRT displays, the picture contrast of these monitors is affected less by ambient light, allowing clear images to be viewed even under strong sunlight. For further protection, the optional VF-509 ENG Kit provides a Viewing Hood, Carrying Handle, and Connector Protector.



LMD-9020 with the VF-509 ENG Kit

4:3/16:9 Switchable Display

With the entry-level type LUMA monitors, the scan aspect ratio can be switched between 4:3 and 16:9.

Convenient Installation

Mounting Flexibility

Mountable in a 19-inch EIA Standard Rack

All entry-level type LUMA monitors can be mounted in a 19-inch EIA standard rack using optional mounting brackets. The 9U-high LMD-2030W uses the MB-529 Mounting Brackets, and the 7U-high LMD-1530W uses the MB-533 Mounting Brackets. The LMD-9020 is 5U high and half-rack wide. Using the optional MB-525 Mounting Bracket with a nine-step tilt capability, two units can be installed side by side in a 19-inch EIA standard rack.

VESA Mounting

Complying with VESA standards, the LMD-2030W and LMD-1530W monitors can easily be mounted (100 x 100 mm pitch) on a wall or ceiling.

Other Features

- Setup Level for Analog Component and NTSC signals
- Blue-Only Mode
- External Sync IN (LMD-2030W and LMD-1530W only)
- 4:3 Zoom (LMD-9020 only)
- Sub Control on Contrast, Chroma, Phase, and Brightness (LMD-9020 only)
- Power-saving function (LMD-9020 only)
- Monochrome mode (LMD-9020 only)



LMD-9020 with MB-525 Mounting Bracket and MB-528 Mounting Panel

Optional Accessories



BKM-250TG
3G/HD/SD-SDI Closed Caption Adaptor (for LMD-2451W only)



BKM-244CC
HD/SD-SDI Closed Caption Adaptor (for high-grade type)

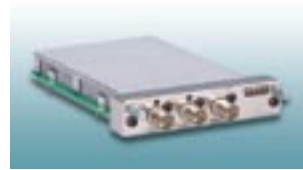

BKM-243HS
HD/SD-SDI Input Adaptor (for high-grade type)



BKM-220D
SD-SDI 4:2:2 Input Adaptor (for high-grade type)



BKM-229X
Analog Component Adaptor (for high-grade type)



BKM-227W
NTSC/PAL Input Adaptor (for high-grade type)



SU-561
Mounting Stand (for LMD-1750W)



MB-529
Mounting Bracket (for LMD-2050W and LMD-2030W)



MB-530
Mounting Bracket (for LMD-1750W)



MB-531
Mounting Bracket (for LMD-940W)



MB-532
Mounting Panel (for LMD-940W)



VF-510
ENG Kit (Viewing Hood, Carrying Handle and Connector Protector) (for LMD-940W)



BKM-320D
SD-SDI Input Adaptor (for LMD-2030W and LMD-1530W)



MB-533
Mounting Bracket (for LMD-1530W)



MB-525
Mounting Bracket (for LMD-9020)



MB-528
Mounting Panel (for LMD-9020)



VF-509
ENG Kit (Viewing Hood, Carrying Handle and Connector Protector) (for LMD-9020)

Feature Comparison

High-grade Type					
Model No.	LMD-4250W	LMD-2451W	LMD-2050W	LMD-1750W	LMD-940W
PANEL Type	a-Si TFT Active Matrix				
Picture Size*1	42-inch	24-inch	20-inch	17-inch	9-inch
Picture Resolution	1920 x 1080 pixels	1920 x 1200 pixels	1680 x 1050 pixels	1280 x 768 pixels	800 x 480 pixels
Panel Aspect Ratio	16:9	16:10		15:9	
Colors	Approx. 16.7 million colors				
INPUT/OUTPUT CAPABILITY	HD (Digital/Analog)/SD (Digital/Analog)				
Acceptable Computer System	Full HD	upto WUXGA	upto WSXGA+	upto WXGA	No
ANALOG VIDEO					
Composite	BNC x 1 (IN), BNC x 1 (OUT*2)				
Y/C	4-pin Mini-DIN x 1 (IN), 4-pin mini-DIN x 1 (OUT*2)				-
Component/RGB	BNC x 3 (IN), BNC x 3 (OUT*2)				-
HD-15	D-sub 15-pin x 1 (IN)				-
External Sync	BNC x 1 (IN), BNC x 1 (OUT*2)				-
DIGITAL INTERFACE					
SD-SDI Input	BKM-220D, BKM-243HS				BNC x 1
HD-SDI Input	BKM-243HS				
3G-SDI	-	BKM-250TG	-		
SDI with Audio Decoding	Yes				
HDMI	No				Yes
DVI-D	DVI-D x 1 (IN)				-
Option Board	2 slots (BKM-244CC, BKM-243HS, BKM-220D, BKM-229X, BKM-227W, BKM-250TG*3)				-
Control					
Parallel	Modular 8-pin x 1				
Serial	D-sub 9-pin (RS-232C) x 1, RJ-45 modular connector (LAN, 10BASE-T/100BASE-TX) x 1				RJ-45 modular connector (LAN, 10BASE-T/100BASE-TX) x 1
Audio					
Audio Input/Output	Phono Jack x 2 (IN), Phono Jack x 2 (OUT)				Stereo Mini jack x 2 (IN/OUT) Head phone x 1
Built-in Speaker Out	1.0 W + 1.0 W Stereo				0.5 W Monaural
Features					
Signal Processing	10 bit				
Color Matching	ChromaTRU				
Marker	Aspect, Center, Safety Area				Aspect, Center, Display size
Color Temperature	9300k, 6500k, user				
Closed Caption	EIA608 (standard), EIA708 (BKM-244CC)				-
Aspect Switch	16:9, 4:3				
Scan	0%, 5%				
Blue Only	Yes				
H/V Delay	Yes				
Tally	No	3-Color			
Smart APA	Yes				No
EIA 19-inch Rack Mounting	Not Applicable		MB-529	MB-530	MB-531
VESA Mounting	400 x 400 mm	100 x 100 mm		100 x 100 mm, 75 x 75 mm	-
Desk-top Stand	No	Supplied		SU-561	Supplied
DC Operation	No				12 V
Application	MED EDU COR CC GOV ENT				

*1 Viewable area, measured diagonally. *2 Loop-Through, Automatic Termination. *3 BKM-250TG supports the LMD-2451W only.

Application Icons

- MED Medical
- EDU Education
- COR Corporate
- CC Content Creation
- GOV Government
- SEC Security
- ENT Entertainment
- SYS System Integrator
- FAC Factory

Entry-level Type			
Model No.	LMD-2030W	LMD-1530W	LMD-9020
PANEL Type	a-Si TFT Active Matrix		
Picture Size*1	20-inch	15.3-inch	8.4-inch
Picture Resolution	1680 x 1050 pixels	1280 x 768 pixels	640 x 480 pixels
Panel Aspect Ratio	16:10	15:9	4:3
Colors	Approx. 16.7 million colors		
INPUT/OUTPUT CAPABILITY	HD (Digital/Analog)/ SD (Digital/Analog)		HD (Analog)/ SD (Analog)
Acceptable Computer System	DVI Input Signals via HDMI		No
ANALOG VIDEO			
Composite	BNC x 1 (IN), BNC x 1 (OUT*2)		BNC x 2 (IN), BNC x 2 (OUT*2)
Y/C	4-pin Mini-DIN x 1 (IN), 4-pin mini-DIN x 1 (OUT*2)		
Component/RGB	BNC x 3 (IN), BNC x 3 (OUT*2), RCA Phono Jack x 1 (IN), RCA Phono Jack x 1 (OUT*2)		BNC x 3 (IN), Mini Jack x 1 (IN)
External Sync	BNC x 1 (IN), BNC x 1 (OUT*2)		BNC x 1 (IN)
DIGITAL INTERFACE			
SD-SDI Input	BKM-320D, RCA Phono Jack x 1 (IN)		No
HD-SDI Input	No		
SDI with Audio Decoding	No		
HDMI	Yes		No
DVI-D	DVI Input Signals via HDMI		No
Option Board	D-sub 9-pin x 1, (BKM-320D IN)		No
Control			
Parallel	Modular 8-pin x 1		
Audio			
Audio Input/Output	RCA Phono Jack x 1 (IN), RCA Phono Jack x 1 (OUT*2)		Mini Jack x 2 (IN), Mini Jack x 1 (OUT), Headphone x 1
Built-in Speaker Out	0.5 W Mono		
Features			
Signal Processing	8 bit		
Marker	Aspect, Center		
Color Temperature	High, Low, User		
Closed Caption	No		
Aspect Switch	16:9, 4:3		
Scan	-3%, 5%		-3%, 0%, 5%
Blue Only	Yes		
H/V Delay	No		
Tally	3-Color		
EIA 19-inch Rack Mounting	MB-529	MB-533	MB-525, MB-528
VESA Mounting	100 x 100 mm		No
Desk-top Stand	Supplied		
Li-ion Battery Operation	No		Yes
DC Operation	No		Yes
Application			

*1 Viewable area, measured diagonally. *2 Loop-Through, Automatic Termination.

Specifications

High-grade Type



LMD-4250W



LMD-2451W

Picture Performance		
Type	A-Si TFT Active Matrix LCD	
Resolution	1920 x 1080 pixels (Full HD)	1920 x 1200 pixels (WUXGA)
Picture Size (H x W) (Viewable area) (Diagonal)	Approx. 930 x 523 mm (Approx. 36 5/8 x 20 5/8 inches) Approx. 1067 mm (Approx. 42 inches)	Approx. 518.4 x 324.0 mm (Approx. 20 1/2 x 12 1/8 inches) Approx. 613.2 mm (24.1 inches)
Aspect	16:9	
Colors	Approx. 16.7 million colors	
Viewing Angle	88°/88°/88°/88° (typical) (up/down/left/right contrast>10:1)	89°/89°/89°/89° (typical) (up/down/left/right contrast>10:1)
Input		
Standard	BNC x 1, 1.0 Vp-p ±3dB sync negative	
Y/C	4pin Mini DIN x 1 Y: 1.0 Vp-p ± 3dB sync negative, C: 0.286 Vp-p ± 3dB (NTSC burst signal level), 0.3 Vp-p ± 3dB (PAL burst signal level)	
RGB, Component	BNC x 3 RGB : 0.7 Vp-p ± 3dB (Sync On Green, 0.3 Vp-p sync negative) Component : 0.7 Vp-p ± 3dB (75% chrominance standard color bar signal)	
External Sync	BNC x 1	
Audio	0.3 to 4.0 Vp-p ± bipolarity ternary or negative polarity binary	
HD15	RCA phono pin x 2 (L, R) -5 dBu 47 k Ω or higher	
DVI-D	TMDS signal link w/HDCP	TMDS signal link (fv:50.0 to 85.1 Hz, fh:31.5 to 77.0 kHz, Dot Clock:25.175 – 162.000 MHz)
Parallel remote	Modular connector 8 pin x 1 (pin assignment at users' allocation)	
Serial remote (LAN)	D-sub 9-pin (RS232C) x 1, RJ-45 modular connector (ETHERNET) x 1 (10BASE-T/100BASE-TX)	
DC in	–	XLR type 4pin x 1 DC24V (output impedance 0.005 Ω or less)
Optional	Option input slot	–
Option input slot	2 slots (for HD-SDI, SDI capability and extra analog I/O's)	
Output		
Standard	BNC x 1, Loop-though, with 75 Ω automatic termination	
Y/C	4pin mini DIN x 1 Loop-though, with 75 Ω automatic termination	
RGB, Component	BNC x 3, Loop-though, with with 75 Ω automatic termination	
External Sync	BNC x 1, Loop-though, with 75 Ω automatic termination	
Audio monitor out	RCA phono pin type x 2 (L, R)	
Speaker (Built-in)	1.0 W + 1.0 W (stereo)	
General		
Power Requirement	AC100 V to 240 V 50/60 Hz 2.3 A to 1.1 A	AC100 V to 240 V 50/60 Hz 0.6 A to 1.1 A, DC2 4V 4.6 A
Power Consumption	Maximum Approx. 230 W (with 2 x BKM-229X)	Maximum Approx. 130 W (with 2 x BKM-229X)
Operating Temperature	0 to 35 °C (recommended operation temperature 20 to 30 °C)	
Operating Humidity	30 to 85% (No condensation)	
Storage & Transport Temperature	-20 to 60 °C	
Storage & Transport Humidity	0 to 90 %	
Operating/Storage/Trans. Pressure	700 to 1060 hPa	
Dimensions (W x H x D)		
Dimensions	1027 x 616 x 130 mm (40 1/2 x 24 3/8 x 5 1/8 inches)	602.4 x 497.9 x 269.9 mm (23 3/4 x 19 5/8 x 10 3/4 inches)
Dimensions without stand	–	602.4 x 386.2 x 110.0 mm (23 3/4 x 15 1/4 x 4 3/8 inches)
Display Stand (W x H x D)	–	320.0 x 361.5 x 269.9 mm (12 5/8 x 14 1/4 x 10 3/4 inches)
Mass	With two option boards Approx. 25 kg (55 lb 2 oz) with BKM-229X x 2	Approx. 11.4 kg (25 lb 2 oz) with BKM-229X x 2
	Without option boards Approx. 24.5 kg (54 lb)	Approx. 11.0 kg (24 lb 4 oz)
Supplied Accessories	AC power cord, AC plug holder, Operating Instructions, CD-ROM, Warranty Card, Using the CD-ROM Manual	

High-grade Type



LMD-2050W



LMD-1750W



LMD-940W

Picture Performance			
Type	A-Si TFT Active Matrix LCD		
Resolution	1680 x 1050 pixels (WSXGA+)	1280 x 768 pixels	800 x 480 pixels
Picture Size (H x W) (Viewable area) (Diagonal)	Approx. 433.5 x 272.9 mm (Approx. 17 1/8 x 10 3/4 inches) Approx. 511.1 mm (20 1/8 inches)	Approx. 370 x 222 mm (Approx. 14 5/8 x 8 3/4 inches) Approx. 431 mm (Approx. 17 inches)	Approx. 195 x 117 mm (Approx. 7 3/4 x 4 5/8 inches) Approx. 227 mm (Approx. 9 inches)
Aspect	16:10		15:9
Colors	Approx. 16.7 million colors		
Viewing Angle	89°/89°/89°/89° (typical) (up/down/left/right contrast>10:1)	85°/85°/85°/85° (typical) (up/down/left/right contrast>10:1)	
Input			
Standard	Composite	BNC x 1, 1.0 Vp-p ±3dB sync negative	
	SDI	-	
	Y/C	BNC x 1	
	RGB, Component	-	
	External Sync	-	
	HDMI Input	HDMI x 1	
	Audio	Stereo Mini jack x 1 -5 dBu 47 k Ω or higher	
	HD15	-	
	DVI-D	-	
	Parallel remote	Modular connector 8 pin x 1 (pin assignment at users' allocation)	
	Serial remote (LAN)	RJ-45 modular connector (ETHERNET) x 1 (10BASE-T/100BASE-TX)	
	DC in	-	
Optional	Option input slot	2 slots (for HD-SDI, SDI capability and extra analog I/O's)	
Output			
Standard	Composite	BNC x 1, Loop-through, with 75 Ω automatic termination	
	SDI	-	
	Y/C	4pin mini DIN x 1 Loop-through, with 75 Ω automatic termination	
	RGB, Component	-	
	External Sync	-	
	Audio monitor out	Stereo Mini jack x 1	
	Headphones output	Mini jack x 1	
	Speaker (Built-in)	0.5 W Monaural	
General			
Power Requirement	AC100 V to 240 V 50/60 Hz 0.4 A to 0.8 A, DC24 V 3.3 A	AC100 V to 240 V 50/60 Hz 0.7 A to 0.3 A, DC12 V, 5.7 A	AC100 V to 240 V 50/60 Hz 0.4 A to 0.2 A, DC 12 V, 1.9 A
Power Consumption	Maximum Approx. 95 W (with 2 x BKM-229X)	Maximum Approx. 70 W (with 2 x BKM-229X)	Maximum Approx. 24 W
Operating Temperature	0 to 35 °C (recommended operation temperature 20 to 30 °C)		0 to 40 °C (recommended operation temperature 20 to 30 °C)
Operating Humidity	30 to 85% (No condensation)		
Storage & Transport Temperature	-20 to 60 °C		
Storage & Transport Humidity	0 to 90 %		
Operating/Storage/Trans. Pressure	700 to 1060 hPa		
Dimensions (W x H x D)			
	Dimensions	Approx. 439.5 x 284 x 105 mm (17 3/8 x 11 1/4 x 4 1/4 inches)	Approx. 222.4 x 183.5 x 161.8 mm (8 7/8 x 7 1/4 x 6 3/8 inches)
	Dimensions without stand	-	Approx. 222.4 x 166 x 70 mm (8 7/8 x 6 5/8 x 2 7/8 inches)
	Display Stand (W x H x D)	-	Approx. 193.8 x 17.5 x 161.5 mm (7 3/4 x 23/32 x 6 3/8 inches)
Mass	With two option boards	Approx. 6.4 kg (14 lb 2 oz) with BKM-229X x 2	Approx. 2.6 kg (5 lb 12 oz) (When AC adaptor is installed)
	Without option boards	Approx. 10.1 kg (22 lb 4 oz)	Approx. 2.0 kg (4 lb 6 oz)
Supplied Accessories	AC power cord, AC plug holder, Operating Instructions, CD-ROM, Warranty Card, Using the CD-ROM Manual		AC power cord, AC power adaptor, AC plug holder, Operating Instructions, CD-ROM, Warranty book, Using the CD-ROM Manual

Specifications

Entry-level Type



LMD-2030W



LMD-1530W



LMD-9020

Picture Performance			
Type	A-Si TFT Active Matrix LCD		a-Si TFT Active Matrix LCD with a multi-layer AR-coated protection panel
Resolution	1680 x 1050 pixels (WSXGA+)	1280 x 768 pixels	640 x 480 pixels
Picture Size (H x W) (Viewable area) (Diagonal)	Approx. 433 x 271 mm (Approx. 17 1/8 x 10 3/4 inches) Approx. 511 mm (20.1-inch)	Approx. 334 x 200 mm (Approx. 13 1/4 x 7 7/8 inches) Approx. 390 mm (Approx. 15 3/8 inches)	Approx. 170.9 x 128.2 mm, (Approx. 6 3/4 x 5 1/8 inches) Approx. 213.6 mm (8.4-inch)
Aspect	16:10		4:3
Colors	Approx. 16.7 million colors		
Viewing Angle	89°/89°/89°/89° (typical) (up/down/left/right contrast>10:1)	88°/88°/88°/88° (typical) (up/down/left/right contrast>10:1)	85°/85°/85°/85° (typical) (up/down/left/right contrast>10:1)
Input			
Line A	Composite Y/C 4-pin mini-DIN x 1 Y: 1.0Vp-p ±3 dB C: 0.286 Vp-p ±3 dB (NTSC), 0.3 Vp-p ±3 dB (PAL), sync 0.3 Vp-p negative	BNC x 1, 1.0 Vp-p ±3dB sync negative 4pin Mini DIN x 1 Y: 1.0 Vp-p ± 3dB sync negative, C: 0.286 Vp-p ± 3dB (NTSC burst signal level), 0.3 Vp-p ± 3dB (PAL burst signal level)	BNC x 1, 1.0 Vp-p +3dB, -6 dB sync negative 4-pin mini-DIN x 1 Y : 1.0 Vp-p + 3dB, -6 dB sync negative C : 0.286 Vp-p ±3 dB (NTSC), 0.3 Vp-p ±3 dB (PAL)
Audio in	RCA phono jack x1, -5 dBu 47 kΩ or higher	RCA phono jack x 1 -5 dBu 47 kΩ or higher	Mini jack x 1, -5 dBu 47 kΩ or higher
Line B	Composite Audio in	-	BNC x 1, 1.0 Vp-p +3 dB, -6 dB sync negative Mini jack x 1, -5 dBu 47 kΩ or higher
RGB/Component			
RGB/Component	BNC x 3, 0.7 Vp-p ±3 dB (Sync on Green 0.3 Vp-p, negative: RGB) (75% chrominance standard color bar signal: Component)	BNC x 3 RGB : 0.7 Vp-p ± 3dB (Sync On Green, 0.3 Vp-p sync negative) Component : 0.7 Vp-p ± 3dB (75% chrominance standard color bar signal)	BNC x 3, 0.7 Vp-p ±3 dB (Sync on Green 0.3 Vp-p, negative: RGB) (75% chrominance standard color bar signal: Component)
Audio in	RCA phono jack x 1, -5 dBu 47 kΩ or higher		BNC x 1, 0.3 to 4 Vp-p ± bipolarity ternary or negative polarity binary
Option	D1-SDI Audio in	D-sub 9-pin x 1 RCA phono jack x 1 -5 dBu 47 k Ω or higher	-
External Sync	AUDIO input (RCA phono jack x1), -5 dBu 47 kΩ or higher BNC x1, 0.3 to 4 Vp-p negative polarity binary	BNC x 1, 0.3 to 4.0 Vp-p negative polarity binary	BNC x 1, 0.3 to 4 Vp-p ± bipolarity ternary or negative polarity binary
HDMI input	HDMI x 1		
SDI	-		
Remote	Parallel remote Modular connector 8-pin x1	Modular connector 8 pin x 1 (pin assignment at users' allocation)	Modular connector 8-pin x 1 (Assignable)
Output			
Line A	Composite Y/C DIN 4 pin x 1, Loop-through, with 75 Ω automatic termination	BNC x 1, Loop-through, with 75 Ω automatic termination 4pin mini DIN x 1 Loop-through, with 75 Ω automatic termination	
Audio out	RCA phono jack x1, Loop-through		
Line B	Composite Audio out	-	BNC x 1, Loop-through, with 75 Ω automatic termination
RGB/Component			
RGB/Component	BNC x3, Loop-through, with 75 Ω automatic termination		
Audio out	RCA phono jack x 1, Loop-through		
External Sync	BNC x1, Loop-through, with 75 Ω automatic terminal function		
Built-in speaker output	0.5 W (mono)		
Monitor output	-		
Audio output	-		
Headphones output	-		
Speaker output	0.5 W (Monaural)		
General			
Power Consumption	Approx. 72 W		Approx. 15 W, With AC Adaptor : Approx. 20 W
Power requirement	AC100 to 240 V, 50/60 Hz	AC100 V to 240 V 50/60 Hz Maximum Approx. 40 W 0.6 A to 0.4 A	AC 100 to 240 V, 50/60 Hz, 0.82 to 0.42 A, DC 12 V 1.5 A, Rechargeable Battery Pack
Operating Temperature	0 to 35 °C (recommended operation temperature 20 to 30 °C)		
Operating Humidity	30 to 85% (No condensation)		
Storage & Transport Temperature	-20 to 60 °C		
Storage & Transport Humidity	0 to 90 %		
Operating/Storage/Trans. Pressure	700 to 1060 hPa		
Dimensions (W x H x D)			
Dimensions	Approx. 493 x 408 x 264 mm (19 1/2 x 16 1/8 x 10 1/2 inches)	Approx. 372 x 336 x 264 mm (14 3/4 x 13 1/4 x 10 1/2 inches)	Approx. 216 x 206 x 136.1 mm (8 5/8 x 8 1/8 x 5 3/8 inches)
Dimensions without stand	Approx. 493 x 361 x 87mm (19 1/2 x 14 1/4 x 3 1/2 inches)	Approx. 372 x 288.3 x 100 mm (14 3/4 x 11 3/8 x 4 inches)	Approx. 216 x 230 x 159.5 mm (8 5/8 x 9 1/8 x 6 3/8 inches)
Dimensions with the supplied stand and AC adaptor	-		
Mass	Approx. 2.8 Kg (6 lb 3 oz)		
Panel & Stand	Approx. 9.6 kg (21.2 lb 3 oz)	Approx. 5.9 kg (13 lb)	-
Panel only	Approx. 7.9 kg (17 lb 6 oz)	Approx. 4.2 kg (9 lb 4 oz)	-
With the supplied stand	-		
With the supplied stand and AC adaptor	-		
Supplied Accessories	Display Stand, AC power cord, AC plug holder, Operating Instructions, CD-ROM, Using the CD-ROM Manual, Warranty Card	AC power cord, AC plug holder, Operating Instructions, CD-ROM, Warranty book, Using the CD-ROM Manual	AC adaptor (1), AC Cord (1), AC plug holder (1), Operating instructions (1), CD-ROM (1), Warranty card (1), Using the CD-ROM Manual (1)

Dimensions

High-grade Type

LMD-4250W

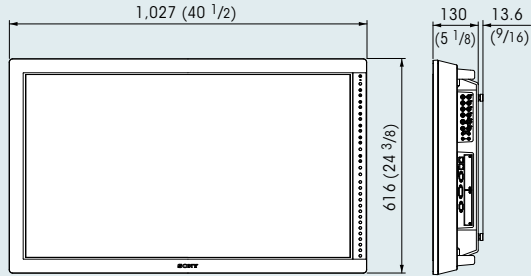

LMD-2451W

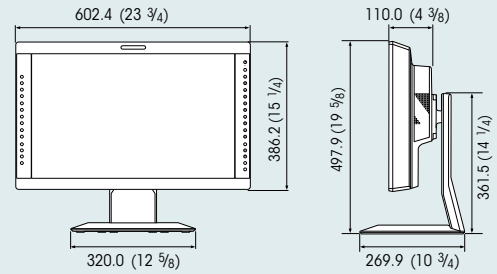

LMD-2050W

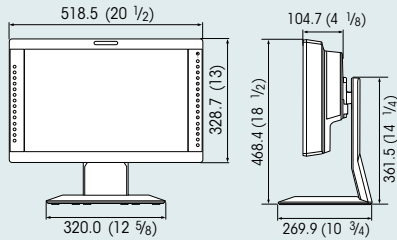

LMD-1750W

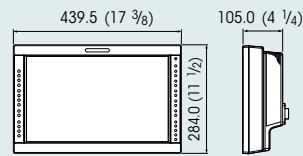

LMD-940W

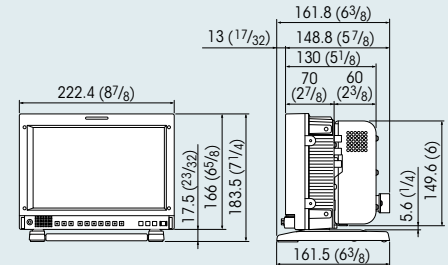

Unit: mm (inches)

Entry-level Type

LMD-2030W

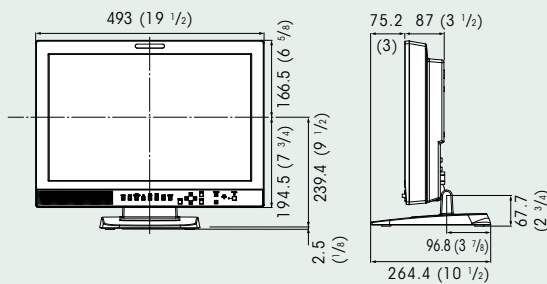

LMD-1530W

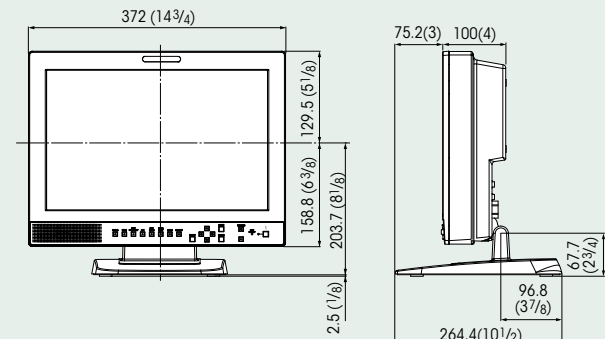

LMD-9020

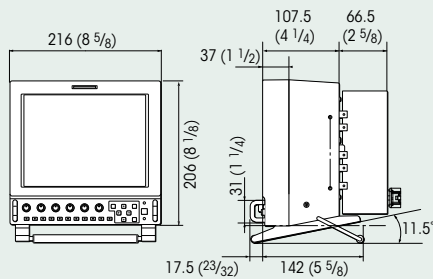

Unit: mm (inches)



SONY



Distributed by

© 2009 Sony Corporation. All rights reserved.
Reproduction in whole or in part without permission is prohibited.
Features and specifications are subject to change without notice.
Images on monitors are simulated.
Sony, ChromaTRU and LUMA are trademarks of Sony Corporation.
All other trademarks are the property of their respective owners.