



Memory Recording Unit
HVR-MRC1K

Hard Disk Recording Unit
HVR-DR60

PROGRESSIVE

HYBRID

Format
Media
Workflow

Streamlining Your Workflow from Acquisition to Editing and Material Archiving with unique HYBRID Recording Solutions from Sony

Speed, reliability, operability, and versatility are key concerns in any video production.

The HVR-MRC1K Memory Recording Unit and HVR-DR60 Hard Disk Recording Unit from Sony offer stunning innovations for all aspects of the production process – from acquisition to editing, and on to material archiving.

The HVR-MRC1K consists of the HVR-MRC1 main unit, HVRA-CR1 cradle, cold-shoe adaptors and an i.LINK cable. Extremely compact and lightweight, the HVR-MRC1 can be mounted on a HDV™/DVCAM™ camcorder, thereby converting it to a 'HYBRID' recording system with CompactFlash® solid-state memory and tape. It allows the user to record video on a tape and CompactFlash (CF) card simultaneously.

The widely available CF card can be used to offer secure recording, removable media convenience, high durability against external vibration, and high-speed file transfer to a computer. It is possible to record for about 72 minutes on a 16-GB CF card.

The Sony HVR-DR60 Hard Disk Recording Unit offers the same HYBRID concept for improving the production process. The HVR-DR60 has a 60-GB HDD which offers a

longer recording time of approximately 4.5 hours (270 minutes) in HDV, DVCAM, or DV recording formats.

There are several very important benefits of HYBRID recording.

HYBRID Format: Simultaneous HD and SD recording
- HD on tape and SD on non-tape media -

HYBRID Media: Use of a tape and non-linear recording media
- For reliable backup recording -

HYBRID Workflow: Files for quick editing and tape for archiving
- For today's production and HD value in the future -

The HVR-MRC1K and HVR-DR60 open up a world of possibilities for digital video production. Whether it's for documentaries, mainstream news, low-budget movies, music videos, Internet, education, or a wide range of industrial applications, Sony's HYBRID solutions are ideal.

Combine the HVR-MRC1K or HVR-DR60 with your HDV or DVCAM camcorder for a true taste of workflow innovation.



HVR-MRC1K



HVR-DR60

HDD
HARD DISK DRIVE



HYBRID Recording



The HVR-MRC1K and HVR-DR60 provide a HYBRID recording capability by which images are recorded to tape and non-linear media simultaneously.

HYBRID Format

It is possible to record video in HD and SD formats simultaneously. When the built-in down-converter of the connected HDV camcorder is active, SD images can be recorded on non-linear media while HD images are recorded to tape.

Alternatively, you can use high-quality uncompressed Linear-PCM audio format data in a DV file instead of compressed audio in HDV material. It is possible to integrate HDV video with Linear-PCM audio on a timeline of HDV-compatible NLE (non-linear editing) software.

HYBRID Media

HYBRID recording allows you to use two different types of recording media at one time. The tape and non-linear media provide backup for each other.

HYBRID Workflow

A tape is still one of the most reliable storage media. HYBRID recording with the HVR-MRC1K or HVR-DR60 allows you to keep the master source tape in a safe place, while having a movie file for streamlined NLE work. You can have both at one time in a single workflow.

HYBRID-Recording

"HD + HD" HYBRID-Recording

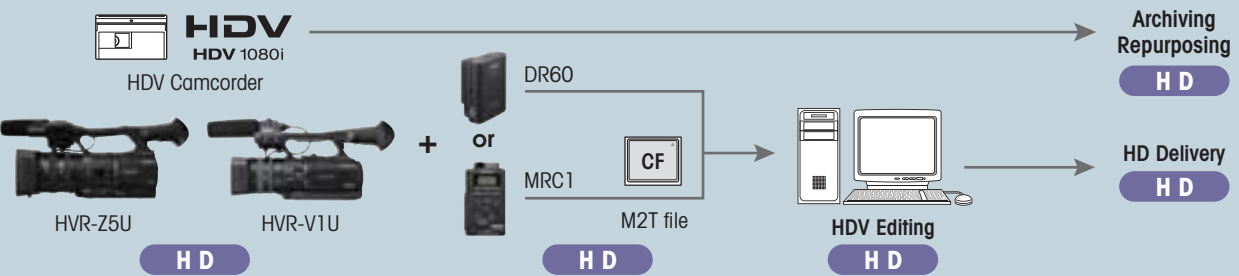

"HD + SD" HYBRID-Recording

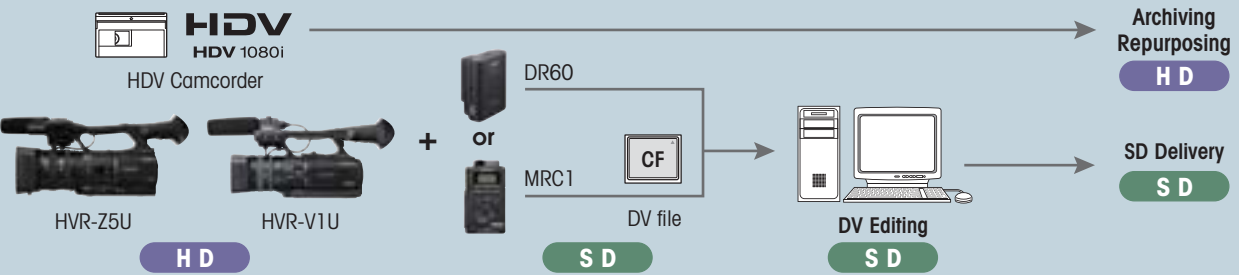

"SD + SD" HYBRID-Recording

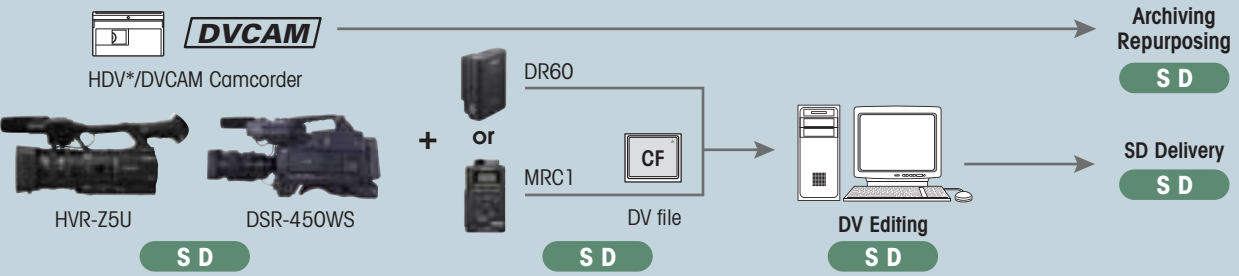

* In DVCAM recording mode

Product Outline

HVR-MRC1K Memory Recording Unit

The HVR-MRC1K is a memory recording unit which consists of the HVR-MRC1 memory recording unit, HVRA-CR1 cradle, cold-shoe adaptors and an i.LINK (IEEE1394) cable. The HVR-MRC1 can be connected directly to the HVR-Z5U without cabling or can be connected to a Sony professional HDV or DVCAM camcorder via an i.Link cable connection. The widely available standard CompactFlash® (CF) card*1 is used for HDV, DVCAM, and DV file recording, with a 16-GB card providing approximately 72 minutes and an 8-GB card providing approximately 36 minutes of recording time.

*1 CF card is not included. At least 133x speed and 2-GB capacity is required. The NCFD8GP and NCFD16GP Sony's CF cards are recommended. The recording time may change according to the CF card type and recording format.



HVR-MRC1 (the CF card is not supplied)

HVR-DR60 Hard Disk Recording Unit

The HVR-DR60 is an optional hard disk recording unit for Sony's professional HDV™ and DVCAM™ camcorders. Via a simple i.LINK cable connection, the HVR-DR60 can record HDV, DVCAM, or DV streams from the camcorder and store them as video files. The internal hard disk drive (HDD) offers a large capacity of 60 GB, which translates into a long recording time of approximately 4.5 hours (270 minutes) for HDV, DVCAM, and DV formats. Images can even be recorded to HDD and tape simultaneously.



HVR-MRC1K and HVR-DR60 Common Features

File Type

For HDV1080i recording

M2T file

This is a file created by the HVR-MRC1 or HVR-DR60. It has the file extension ".M2T". The video, audio and auxiliary data are contained in an MPEG2-TS file format. The file conforms to the HDV1080i specification in which MPEG-2 MP@H-14 is used for its video codec and either MPEG-1 Audio Layer2 (for 2 ch) or MPEG-2 Audio Layer2 (for 4 ch) is used for the audio codec.

For DVCAM and DV recording

There are two options for DVCAM/DV file recording:

AVI file (DV type1)

This file has the extension ".AVI", and can be played by the standard movie player software of both Windows® and Macintosh® operating systems. Using this file type for DVCAM/DV recording is useful because it is compatible with many types of application software.

RawDV file

You can also choose this file type for DVCAM/DV recording, if needed. It has the file extension ".DV", and contains raw DVCAM or DV data. This file type can be played back via the QuickTime Player on the Macintosh® operating system. A compatible player may be needed for playback on the Windows® operating system.

FAT32 File System

The HVR-MRC1 and HVR-DR60 use FAT32 for their file system. Thanks to FAT32, your Windows® or Macintosh® computer can recognize the recording media as an external drive without having to install any driver software. The maximum recording file size allowed with FAT32 is approximately 4 GB, which provides a recording time of around 20 minutes. Should your recording exceed this, the subsequent footage will be recorded as a separate new file. However, the Sony Recording Unit Utility software and compatible NLE software can connect the divided M2T files so they can be edited precisely in your NLE as a single file without any pauses.

✦ Versatile Recording Modes

Three recording modes can be selected to support various camcorder models and operational needs.

SYNCHRO mode

When using camcorders that support external rec control, such as the HVR-Z5U, HVR-V1U, HVR-Z1U, DSR-450WS, DSR-400 and DSR-250, recording to the HVR-MRC1 or HVR-DR60 is directly controlled by the press of the camcorder's rec start button.*²

*² In this mode, a rec start delay of approximately 0.5 seconds may occur after the camcorder rec start button is pressed.

FOLLOW mode

When using camcorders that do not support external rec control, such as the HVR-A1U and DSR-PD170, the FOLLOW mode can be used to start and stop recording of the HVR-MRC1 or HVR-DR60. In this mode, the HVR-MRC1 or HVR-DR60 periodically checks whether the camcorder is in rec mode or not, and follows this status.*³

*³ In this mode, a rec start delay of up to 2 seconds may occur after the camcorder rec start button is pressed.

Independent Recording

The HVR-MRC1 and HVR-DR60 can disregard the rec trigger or recording status of the camcorder and allow recording to be started and stopped using its own control buttons. This allows control of the HVR-DR60 independent of camcorder operations.*⁴

*⁴ In HDV mode, interruptions in time code and video may appear in the recording when the camcorder rec control buttons are pressed.

Supported Camcorder Models

Model	SYNCHRO mode	FOLLOW mode	Independent Recording	HDV	DVCAM	DV
HVR-S270U	○*	○	○*	○	○	○
HVR-Z7U	○*	○	○*	○	○	○
HVR-Z5U	○*	○	○*	○	○	○
HVR-Z1U	○	○	○*	○	○	○
HVR-V1U	○*	○	○*	○	○	○
HVR-A1U	—	○	○*	○	○	○
HVR-HD1000U	—	○	○*	○	—	○
DSR-570WS	○*	○	○*	—	○	—
DSR-450WS	○*	○	○*	—	○	○
DSR-400	○*	○	○*	—	○	○
DSR-390	○*	○	○*	—	○	—
DSR-250	○	○	○*	—	○	○
DSR-PD170	—	○	○*	—	○	○
DSR-PD150	—	○	○*	—	○	○
DSR-PDX10	—	○	○*	—	○	○

*Tape-less recording is also available.

Cache Recording

The HVR-MRC1 and HVR-DR60 offer a cache recording function, in which up to 14 seconds of video and audio are continuously buffered in the memory. This helps prevent the loss of important scenes or events that occur 14 seconds before the rec start button is pressed*⁵, as that footage is automatically recorded to the hard disk or CF card.

*⁵ In HDV mode, approximately 0.5 seconds of the video captured before and after the camcorder rec start button is pressed may be lost.

✦ Control Buttons

The HVR-MRC1 and HVR-DR60 are equipped with buttons that provide control for functions such as record, play, stop, next and previous. Using these buttons, the unit can output HDV/ DVCAM/DV streams with time code via the i.LINK connector.

✦ Quick Review of Recordings

Using the control buttons of the HVR-MRC1 and HVR-DR60, stored footage can be instantly accessed and previewed on the LCD monitor of the connected camcorder or deck for a quick review of recordings.

✦ Repeat Playback

The HVR-MRC1 and HVR-DR60 offer a repeat playback function that allows for one desired clip or all clips to be repeated and transferred via the i.LINK connector to an i.LINK compatible device.

✦ Status Check on Camcorder

On the LCD monitor and viewfinder of the HVR-S270U, HVR-Z7U, HVR-Z5U and HVR-V1U, the operational status of the HVR-MRC1 and HVR-DR60 such as connection, recording format, battery level, remaining recording time, recording folder name, etc. can be checked. This keeps operators informed of both the camcorder and external device status, without taking their eyes away from what is being shot.



External Device Status Check

✦ Tapeless Recording

Some camcorder such as the HVR-Z5U and HVR-V1U send the rec start/stop trigger that controls the HVR-MRC1 or HVR-DR60 without needing loading a tape. This feature offers operators the choice of tapeless operation or HYBRID operation.

HVR-MRC1K Memory Recording Unit

❖ HDV in IT Workflow by CompactFlash Memory Recording Unit

The HVR-MRC1 captures the HDV1080i, DVCAM, or DV stream output from the camcorder and records it as movie file while you are simultaneously recording to tape.

You can use a standard CompactFlash (CF) card*6, which offers secure recording, high-speed access, large data capacity, removable media convenience, and high durability against external vibration.

*6 Not supplied.

The CF card is used for HDV/DVCAM camcorders because the media is easily obtainable for file recording in the same way as miniDV tape is easily obtainable for HDV/DVCAM recording. This general versatility is very important for those who frequently need to obtain media quickly, such as someone shooting a documentary or news reports while moving from city to city.



❖ HDV/DVCAM/DV File Recording on Easily Obtained CompactFlash Card

The recording time on a 16-GB CF card*7 in HDV, DVCAM and DV format*8 is approximately 72 minutes.

CF card capacity	Recording time(approximately)
16GB	72 minutes
8GB	36 minutes
4GB	18 minutes
2GB	9 minutes



72 min.
16 GB

HDV
HDV 1080i

DVCAM

DV Digital Video Cassette

*7 At least 133x speed and 2-GB capacity is required. The NCFD8GP and NCFD16GP Sony CF cards are recommended. With other commonly-used CF cards, there may be rare occasions when data will not be recorded correctly depending on the products.

Such CF cards may have unstable data transfer speed. If you use a CF card other than those recommended, it is advisable to test it in advance in the following way.

- 1) Format the CF card in the Memory Recording Unit.
- 2) Shoot more than 20 pieces of footage of about 10 seconds each in HDV recording mode.
- 3) Import the files into your nonlinear editing software to check if it can be edited properly.

*8 The recording time may change according to the CF card type and recording format.

❖ Integration Without Cabling

The HVR-MRC1 can be integrated to the HVR-Z5U without the need for cabling, simply by attaching it onto the special shoe connector*9.

This smart combination never interferes with shooting operations. The HVR-MRC1 automatically synchronizes with the recording action of the camcorder – i.e., when the camcorder starts or stops recording, so does the unit.

*9 The intelligent shoe connector inputs and outputs an HDV/DV stream and supplies power to the HVR-MRC1. The i.LINK connector is not available when the unit is attached on the camcorder.



attached on the HVR-Z5U



work with other camcorders via an i.LINK cable connection

❖ Independent Use With the Supplied Cradle

The HVR-MRC1 can be used as an external recording unit, just like the HVR-DR60, by attaching the supplied cradle that has an i.LINK connector, battery attachment, and DC power input. When the HVR-MRC1 is connected to a computer via i.LINK (IEEE1394), it is recognized as an external drive and can be used to access files. When connected to a video device (such as a VTR or NLE system) via i.LINK, it can be used to input/output a HDV/DVCAM/DV stream.



❖ File Name and Folder Structure

In the HVR-MRC1, all files are stored in one folder. Each file is named in line with the following format:

`xx_nnnn_YYYY-MM-DD_HHMMSS.extension`
(e.g., 01_0001_2007-10-01_134510.M2T)

xx:

This is a two-digit number (00 - 99) that you can set via the "CAM No." menu of the HVR-MRC1. This prefix number is useful when multiple CF cards are used.

nnnn:

This is a sequential clip number. It is incremented by one as each new recording begins.

YYYY-MM-DD_HHMMSS:

These numbers refer to the date and time of the recording (which are derived from the date and time data settings of the camcorder)*10.

Any subsequent files, divided by FAT32, will have new time data, but retain the same clip number.

*10 The date and time digits of the file name will be listed as "0000-00-00_000000" if the i.LINK signal comes from any of the following devices:

- A camcorder that doesn't have date and time setting
- A camcorder or VCR that is playing back a recorded tape which doesn't contain data and time data
- Other devices that don't output date and time data via an i.LINK stream

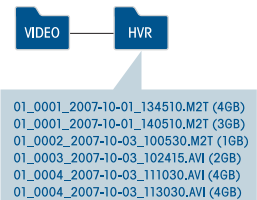

The folder structure and file name created by the Memory Recording Unit

■ File Transfer

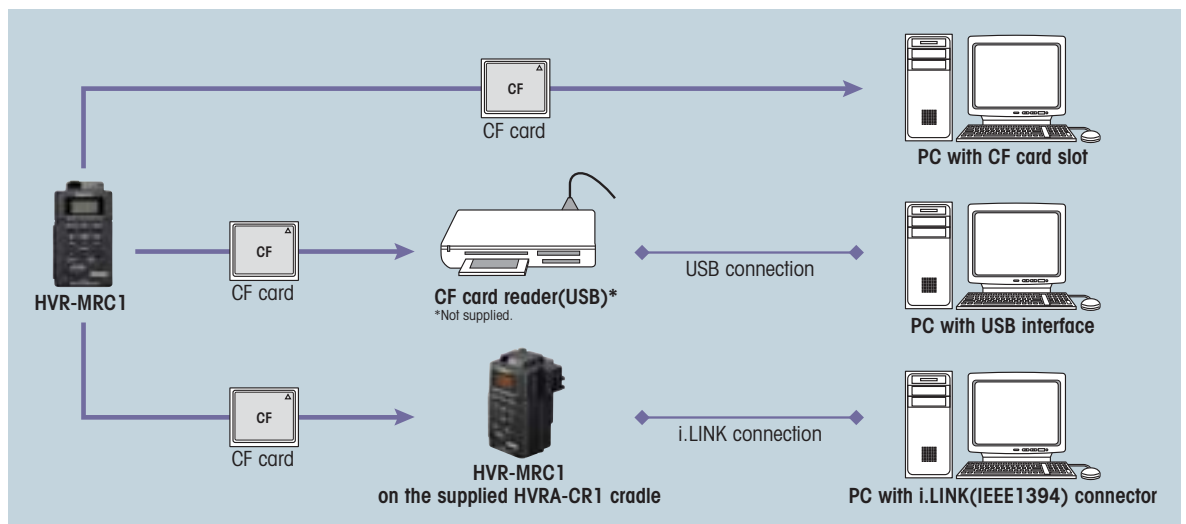

■ Playback from the HVR-MRC1

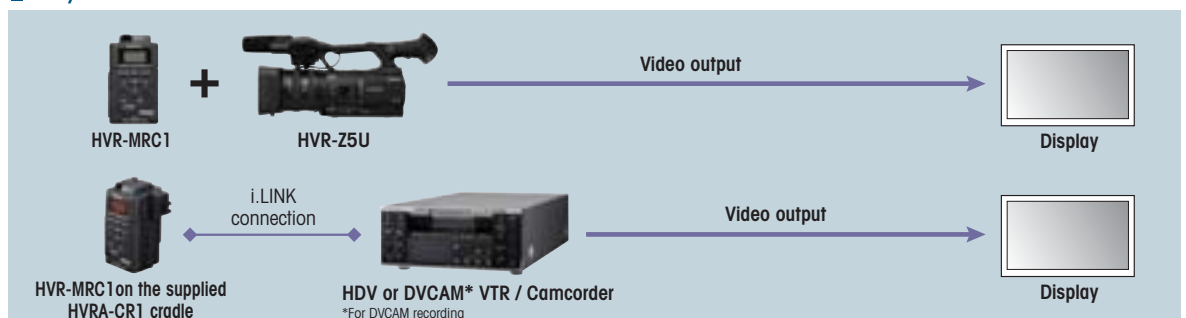

Note: Interruptions in video out put may appear between recordings during playback through the connected HDV/DVCAM/DV device.

HVR-DR60 Hard Disk Recording Unit



❖ Long Recording Time of 4.5 Hours

Via its simple i.LINK^{*11} connection, the HVR-DR60 Hard Disk Recording Unit can record HDV 1080i streams from a compatible HDV camcorder or DVCAM/DV streams from a compatible DVCAM camcorder. The internal 1.8-inch hard disk drive (HDD) offers a large capacity of 60 GB, which translates into a long 4.5 hours (270 minutes) recording time for both formats.

HDV 1080i streams are recorded as native HDV files (.m2t), while DVCAM/DV streams are recorded as DV-AVI (Type1) or RAW-DV files.

*11 i.LINK is a trademark of Sony used only to designate that a product contains an IEEE 1394 connector. Not all products with an i.LINK connector will necessarily communicate with each other. For information on compatibility, operating conditions, and proper connection, please refer to the documentation supplied with any device with an i.LINK connector. For information on devices that include an i.LINK connection, please contact your nearest Sony office.



❖ Long Operating Hours Using Common Camcorder Batteries

The HVR-DR60 uses the same infoLITHIUM™ L Series batteries as the HVR-Z7U, HVR-Z5U and HVR-V1U camcorders. With the smallest capacity NP-F570 battery, the HVR-DR60 can run continuously up to 5.5 hours (330 min), and with the largest capacity NP-F970, this increases up to 18 hours (1080 min). Long operating hours are offered using the same camcorder batteries HDV operators already have at hand.

❖ Compact and Lightweight

The HVR-DR60 measures just 81 x 45 x 100 mm (3 1/4 x 1 3/4 x 4 inches) in size and only about 230 g (8 oz) in weight. It can be mounted on a camcorder's cold shoe using the supplied shoe adapter, or attached using an optional VCT-1BP Bracket.

❖ HDD Smart Protection – Robust Recording and Shock Resistance

Three advanced technologies are used in the HVR-DR60 to provide reliable recording performance:

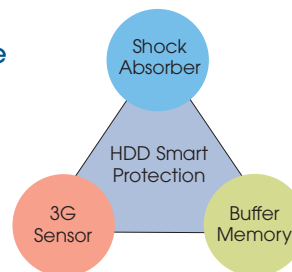

1) Rubber shock absorbers hold the HDD unit in place, helping to prevent external shock from being transmitted when the HVR-DR60 chassis is subject to impact.

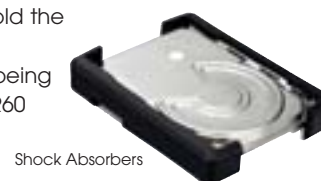

Shock Absorbers

2) A 3G sensor detects gravitational acceleration in three dimensions, so however the HVR-DR60 may be oriented, the sensor can detect if it has been dropped. Should this occur, power to the HDD is shut off and the recording heads are retracted



3G sensor

from the disk platter, pausing read/write operations. This helps protect the HDD from being damaged when the unit is accidentally dropped and subject to strong impact.

3) A buffer memory can store approximately 14 seconds of video and audio footage. Recordings are made by first writing the data to the buffer, and then writing the buffer data to the disk platter. Consequently, if the 3G sensor temporarily interrupts disk writes, video footage is not lost. Thanks to such advanced technologies, the HVR-DR60 should continue to record stably even when dropped from as high as 100 cm (39 3/8 inches) (based on Sony's testing).

❖ User-free Area

The HVR-DR60 has a user-free area of approximately 1 GB in the hard disk, where common data files such as still images and project files of nonlinear editing systems can be stored.

✦ File Name and Folder Structure

The HVR-DR60 creates a folder (e.g., "100HDVF") when recording begins, and stores recorded video within it as a movie file (e.g., "HDV10001.M2T"). Any subsequent files divided FAT32, are stored in the same folder (e.g., "HDV10002.M2T"). When a new recording is made, a new folder (e.g., "101HDVF") is created and a new file (e.g., "10101.M2T") is stored within it.

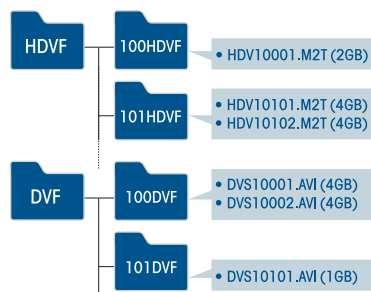

The folder structure and file name in the HVR-DR60

■ File Transfer

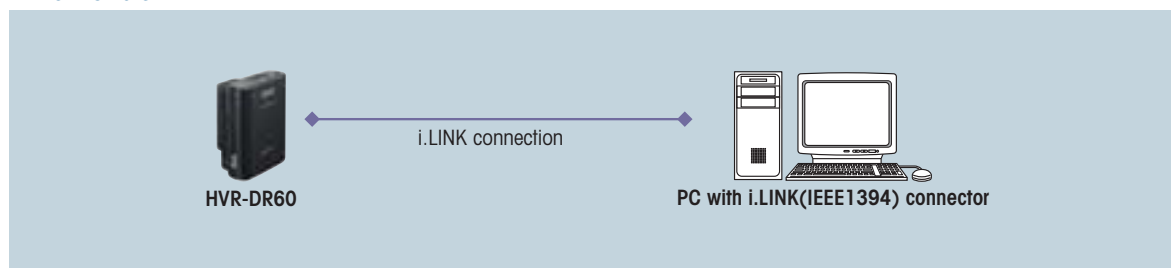

■ Playback from the HVR-DR60

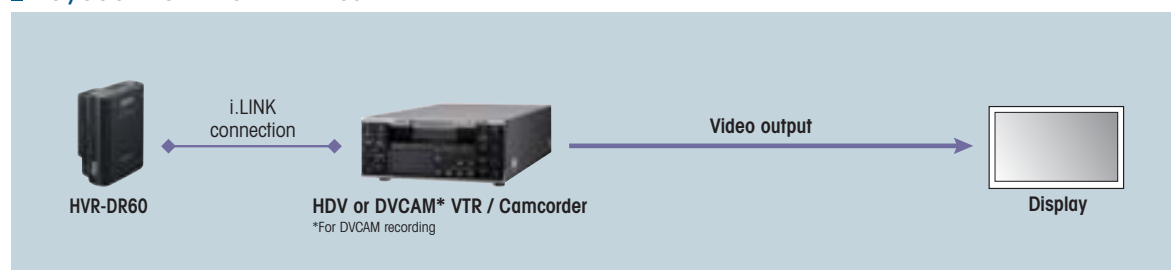

Note: Interruptions in video out put may appear between recordings during playback through the connected HDV/DVCAM/DV device.



Sony Recording Unit Utility

This software can be downloaded from Sony’s website free of charge. It allows you to transfer the files on your HVR-DR60 and CF card to your Windows-based PC with ease. It can connect M2T files, that were divided by FAT32, back together, and it will rename HVR-DR60 files to the same style as those from a CF card during transfer.

Overview of the functions

File transfer

The HVR-DR60 creates a folder (e.g., “100HDVF”) when recording begins, and the recorded video is stored in that folder as a movie file (e.g., “HDV10001.M2T”). When a new recording is made, a new folder (e.g., “101HDVF”) is created and a new file (e.g., “10101.M2T”) is stored within it.

You can then transfer all of these decentralized files to one specified folder on the HDD of your PC, quickly and easily with this utility software. You don’t need to open each folder to import the movie files to your NLE project; simply select the folders where your files are stored and the software will automatically find the files and transfer them.

M2T File connection

The HVR-MRC1 and HVR-DR60 uses FAT32 for its file system. Thanks to FAT32, your PC can recognize the HVR-DR60 as an external drive without needing to install any driver software.

The maximum recording file size allowed with FAT32 is approximately 4GB, which provides a recording time of around 20 minutes. Should your HDV recording exceed this, the subsequent footage will be recorded as a new file stored within the same folder.

The software connects these divided .M2T files together during transfer so they can be edited precisely in your NLE as a single file without any pauses.

*DV files are not connected because the divided DV files can be edited precisely in your NLE.

File name change

For the HVR-DR60, the software automatically changes the name of the transferred file, in line with the following format:

“xx_nnnn_YYYY-MM-DD_HHMMSS”.

xx:

This is a two-digit number (00 – 99) that you can set, which is useful for avoiding the duplication of file names when using multiple HVR-DR60 units.

nnnn:

These numbers corresponded to the original folder name.

YYYY-MM-DD_HHMMSS:

These numbers refer to the date and time of the recording (setup value of the camcorder).



Transfer files to a single folder

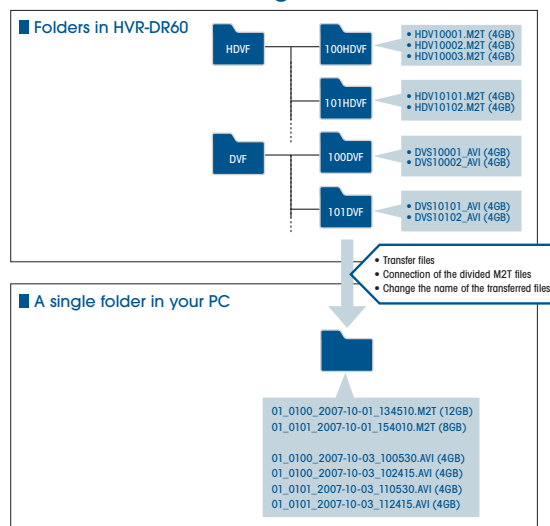

Software Information

OS	Windows® XP SP2 or later , Windows® Vista
Language	English

Notes:

- Some NLEs, such as Sony Vegas (version 7.0c and later) and GrassValley EDIUS Pro4.5, have an import module that lets you import files directly from the HVR-MRC1 or HVR-DR60 to your PC’s hard drive. During the import process, these software will merge all divided .M2T files into a single, seamless .M2T file.
- If the destination folder is not on an NTFS-formatted hard drive, the merged file can not be output. This software can only merge files that are divided by FAT32 specification.
- If the destination hard drive is full, file merging will stop. Please check the remaining capacity of your PC’s hard drive before using this software.

Sony Recording Unit RAD Plug in For Final Cut Pro® 6 (Macintosh®)

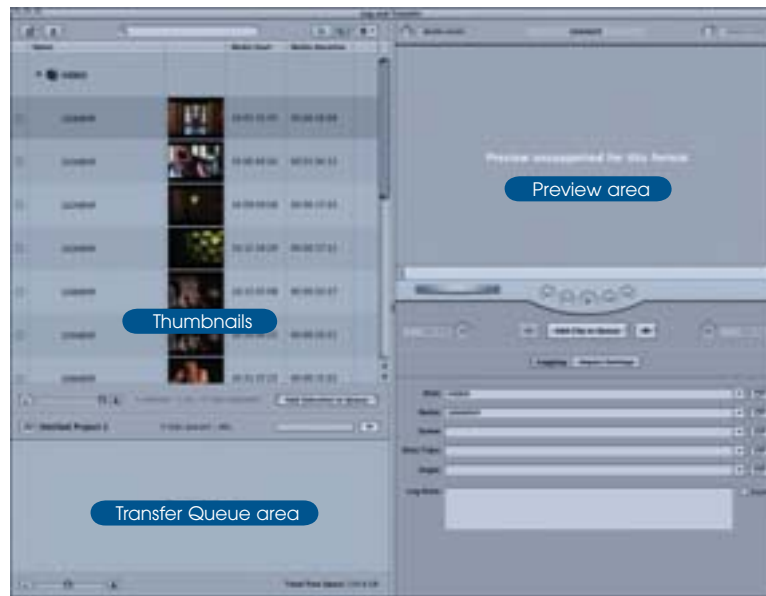

Log and Transfer window

For Quick File Import to Final Cut Pro

M2T and DVCAM/DV files stored on the HVR-DR60 and the CF card of the HVR-MRC1 can be imported correctly to your Final Cut Pro 6 project by installing the Sony Recording Unit RAD Plug in software. This software allows the video and audio stored on these devices to be transferred into Final Cut Pro using the Log and Transfer feature.

Please ensure that your version of Final Cut Pro is upgraded to 6.0.2 or higher before installing this plug-in software.

The plug-in software can be downloaded from Sony's website.

- For detailed operating instructions of Final Cut Pro 6 and its Log and Transfer window, please ask your local Apple reseller or refer to the "Using the Log and Transfer Window" section of the HD and Broadcast Formats document. This document is available under Final Cut Pro's Help menu.



Use the Log and Transfer window

- 1 Choose Final Cut Pro > System Settings, then click the Scratch Disk tab.
- 2 Select a scratch disk or folder to which you want to transfer your media
- 3 Choose File > Log and Transfer.
- 4 The contents and thumbnails of the mounted devices will appear automatically in the Log and Transfer window. If the file structure of the device has been copied into a different location, you can use the "Add Folder" button on the upper left corner. More information on using the Add Folder button can be found in the Final Cut Pro documentation.
- 5 Please select the files that you want to transfer, then press the "Add Selection to Queue" button or drag and drop them onto the Transfer Queue area.

Note: the preview area is not available for the M2T file transfer.

- 6 The transfer will start and the files will appear in the bin window of the editing project. The transferred files maintain their original quality and their original time code data in the QuickTime® format. The FAT32 divided files are merged during transfer.
- 7 For files recorded in 24A scan mode on the HVR-S270U/Z7U/Z5U/V1U, the Log and Transfer window automatically removes the 2-3 cadences and transcodes the HDV data to the Apple ProRes 422 codec during transfer in order to edit the footage in the 23.98p timeline. This takes longer than the normal transfer of 60i recordings. For details of the Apple ProRes 422 codec, please refer to the latest version of the Final Cut Pro user manual.

Specifications

HVR-MRC1K		
Recording media	Compact Flash	At least 133x speed and 2-GB capacity is required. The SONY CF card is recommended.
Interface	i.LINK with HVRA-CR1	IEEE 1394, 6-pin connector
File format	DVCAM/DV SP	MPEG-2-TS (.m2t) AVI-Type1 (.AVI), RAW-DV (.DV)
Built-in output device	LCD monitor	23.02 x 11.5 mm (picture size), 128 x 64 dots
OS compatibility	OS	Windows® 2000 Professional (Service Pack 4), Windows XP Home Edition (Service Pack 2), Windows XP Professional (Service Pack 2), Windows Vista, Mac® OS X (v10.3)
General	Mass	HVR-MRC1 130g(4 oz) HVR-MRC1 with HVRA-CR1 210g(7 oz)
	Power requirements	DC 7.2 V (battery pack), DC 8.4 V (AC adaptor)
	Power consumption	2.2 W (in recording mode with LCD monitor on)
	Operating temperature	0 to 40 °C (32 to 104 °F)
	Storage temperature	-20 to +60 °C (-4 to 140 °F)
	Supplied accessories	i.LINK cable (6-pin to 4-pin, 80 cm), Shoe adaptor, Conversion adaptor for HVR-Z1, HVRA-CR1 (cradle)

HVR-DR60		
Hard disk drive	Recording capacity	60 GB*
	Disk size	1.8 inches
	File system	FAT32
Interface	i.LINK	IEEE 1394, 6-pin connector
File format	HDV	MPEG-2-TS (.m2t)
	DVCAM/DV SP	AVI-Type1 (.AVI), RAW-DV (.DV)
Built-in output device	LCD monitor	23.02 x 11.5 mm (picture size), 128 x 64 dots
OS compatibility	OS	Windows® 2000 Professional (Service Pack 4), Windows XP Home Edition (Service Pack 2), Windows XP Professional (Service Pack 2), Windows Vista, Mac® OS X (v10.3)
General	Mass	230 g (8 oz)
	Power requirements	DC 7.2 V (battery pack), DC 8.4 V (AC adaptor)
	Power consumption	2.7 W (in recording mode with LCD monitor on)
	Operating temperature	0 to 40 °C (32 to 104 °F)
	Storage temperature	-20 to +60 °C (-4 to 140 °F)
	Supplied accessories	i.LINK cable (6-pin to 4-pin, 80 cm), Shoe adaptor, Operating instructions

*In this specification, 1GB indicates 1 billion bytes. A portion of the recording capacity is used for data management.



HVR-MRC1K



HVR-DR60

Dimensions

Unit: mm (inches)

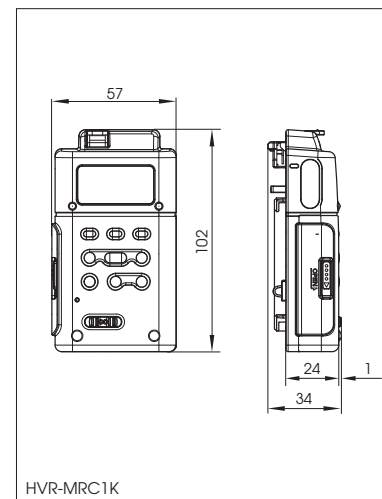

HVR-MRC1K

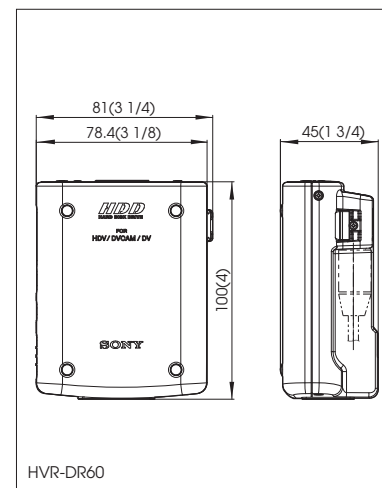

HVR-DR60

Accessories

•For HVR-MRC1K and HVR-DR60
NP-F970/F770/F570
2NP-F970B (two packs of the NP-F970)
 InfoLITHIUM Rechargeable Battery Pack

AC-VQL1BP
 AC-Adaptor / Charger

VCT-1BP
 Bracket
 (for HVR-Z7U/Z5U/
 Z1U/V1U, DSR-PD170)

•For HVR-MRC1K
 CompactFlash card
NCFD8GP (8GB,306x)
NCFD16GP (16GB,306x)



VCT-1BP

Distributed by

© 2008 Sony Corporation. All rights reserved.
 Reproduction in whole or in part without permission is prohibited.
 Features and specifications are subject to change without notice.
 All non-metric weights and measurements are approximate.
 Sony, DVCAM, i.LINK, InfoLITHIUM and their respective logos are trademarks of Sony Corporation.
 HDV and the HDV logo are trademarks of Sony Corporation and Victor Company of Japan, Limited.
 Windows is a registered trademark of Microsoft Corporation.
 Macintosh, Final Cut Pro and Quick Time are registered trademark of Apple Inc.
 All other trademarks are the property of their respective owners.